

weka

Montageanleitung für Geräteschrank

GB	Assembly instructions
F	notice de montage
I	istruzioni di montaggio
E	Instrucciones de montaje
P	Instruções de montagem

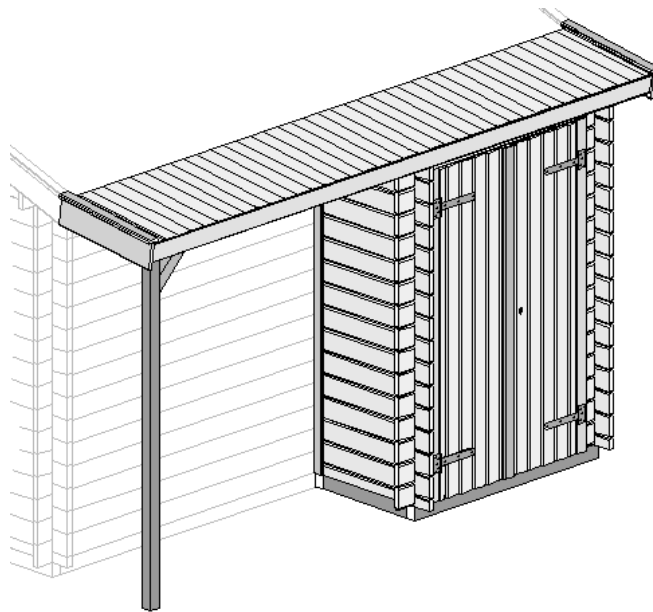

Art.-Nr.: 100.0401.00.00

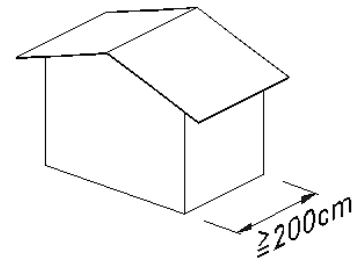

Art.-Nr.: 100.0402.00.00

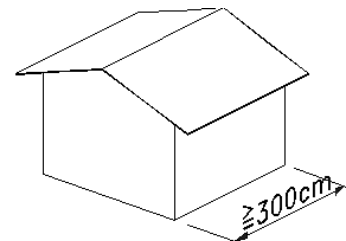

Art.-Nr.: 100.0403.00.00

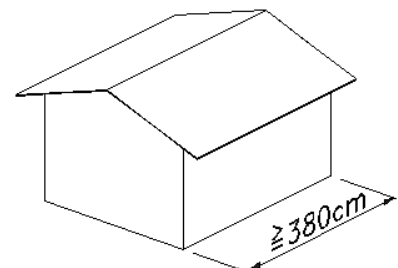

Stand: 2616

- D -

**Sehr geehrte Kundin, sehr geehrter Kunde,
danke, daß Sie sich für ein Produkt entschieden haben.**

Lesen Sie diese Anleitung vor dem Aufbau bitte vollständig durch, um Montagefehler oder Beschädigungen zu vermeiden.

WICHTIG !

Prüfen Sie bitte sofort anhand der Packliste, ob das Produkt vollständig und unbeschädigt bei Ihnen angekommen ist.

Bitte vernichten Sie die Packliste erst nach Ablauf der Garantiezeit. Diese Liste dient Ihnen zur Kontrolle auf Vollständigkeit der Einzelteile und ist mit dem Kaufbeleg aufzubewahren. Eventuelle Beanstandungen können mit Hilfe dieser Liste problemlos behoben werden. Die Pos.-Nummern der Packliste stimmen nicht mit den Pos.-Nummern folgender Montageanleitung überein.

Wir empfehlen Ihnen, die Montage mit 2 Personen durchzuführen.

Zur Verhütung von Unfällen ist zu vermeiden, daß sich Kinder während der Montage in unmittelbarer Nähe aufhalten.

Weiterentwicklungen im Sinne des technischen Fortschritts behalten wir uns vor. So können geringfügige Abweichungen in den Darstellungen entstehen.

Bitte bohren Sie alle Schraubverbindungen vor, um Beschädigungen an den Holzteilen zu vermeiden! Folgendes Zeichen macht Sie während der Anleitung nochmals darauf aufmerksam:

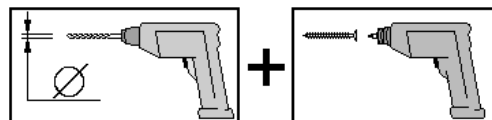

Hinweise zur Montage am Haus

Jeder Anbauschrank kann links oder rechts am Haus montiert werden.

Die Montage kann gleichzeitig mit dem Haus erfolgen, aber auch jederzeit später als Erweiterung durchgeführt werden.

Der Pfosten kann je nach Untergrund eingegraben oder auf einem Fundament befestigt werden.

Die Verankerung gehört nicht zum Lieferumfang!

Holzschutz

Das Produkt besteht aus dem natürlichen Rohstoff Holz. Dies macht regelmäßig ausreichende Holzschutzmaßnahmen zwingend erforderlich. Für die fachgerechte Holzschutzbehandlung wenden Sie sich bitte an einen Holzschutzfachmann.

Holzschutzmaßnahmen sind vom Kunden in eigener Verantwortlichkeit durchzuführen. Ohne vorschriftsmäßigen Holzschutz kann keine Gewährleistung übernommen werden. Bitte beachten Sie auch die diesbezüglichen Bestimmungen in unseren Garantieerklärungen.

Wir wünschen Ihnen viel Freude mit Ihrem Holzprodukt.

Folgendes Werkzeug sollten Sie vor Beginn der Montage zurecht gelegt haben.

Rollmaß

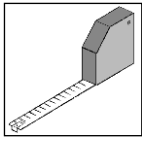

Bohrmaschine

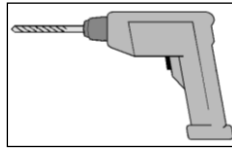

Elektroschrauber

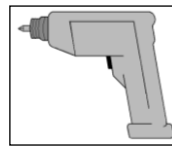

Feinsäge /
Handkreissäge

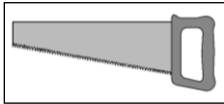

Universalmesser

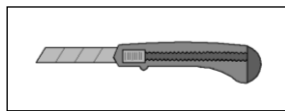

Hammer



- GB -

Dear customer

Thank you very much for choosing a product.

Read these instructions through completely before assembling your product in order to avoid errors in assembly or damage.

IMPORTANT

Please use the enclosed packing list to check immediately that your product has been delivered complete and intact.

Please do not dispose of the packing list before the guarantee period has expired. This list enables you to check that all the individual parts are present. It should be retained along with the proof of purchase. Any complaints which may arise can probably be easily rectified with this list. The item numbers on the packing list do not correspond to the item numbers in the following assembly instructions.

We recommend that 2 people carry out the assembly.

In order to prevent accidents, we recommend that children are kept out of the direct vicinity during assembly.

We reserve the right to make further technological developments. This means that there may be minor deviations in the illustrations.

Please drill pilot holes for all screw connections to avoid damaging the wood. The following symbol in the instructions will indicate when this is necessary:

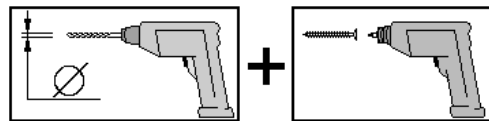

Information on mounting on an existing structure

Each extension cabinet can be mounted to the left or right on the structure.

Assembly can be carried out at the same time as the structure is erected, but it can also be added later as an extension.

Depending on the substrate, the studs can be buried or fixed to a foundation.

Wood protection

The product is made from natural timber, for which regular and adequate wood preservation measures are obligatory. Please contact a wood preservation expert for information on professional preservation measures.

Wood preservation is to be carried out by the customer at his own risk. No guarantee can be given in the event of wood preservation not carried out in accordance with the instructions. Please also note the provisions relating to this in our guarantee. We wish you much pleasure with your wood product.

You should have the following tools to hand before beginning assembly.

Spring tape measure/
measuring tape

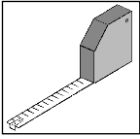

Drill

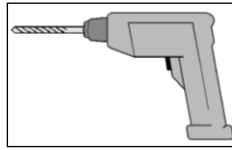

Electric
screwdriver

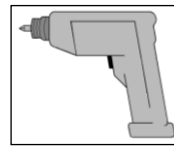

Mitre saw/
hand disk saw

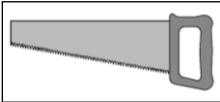

Universal cutter

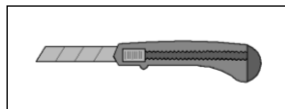

Hammer



- F -

Chère Cliente, cher Client

Nous vous remercions d'avoir choisi un produit.

Lisez entièrement la présente notice avant de procéder à l'assemblage afin d'éviter les erreurs et les dommages.

IMPORTANT !

Veillez vérifier immédiatement, à l'aide de la liste des pièces, si le produit est arrivé complet et en bon état.

Ne détruisez la liste des pièces qu'une fois la garantie écoulee. Cette liste vous permet de vérifier si les pièces détachées sont complètes et doit être conservée avec le justificatif d'achat. Elle vous permettra de faire valoir aisément d'éventuelles réclamations. Les numéros de pos. de la liste des pièces ne sont pas identiques aux numéros de pos. de la présente notice de montage.

Nous vous recommandons d'effectuer le montage à 2 personnes.

Afin de prévenir tout accident, éviter la présence d'enfants à proximité durant le montage.

Nous nous réservons le droit d'apporter aux produits des modifications dans le cadre de l'évolution technique. De légères différences sont par conséquent possibles par rapport aux illustrations.

Pré-percez tous les assemblages vissés afin d'éviter d'endommager les éléments en bois!

Ceci vous est rappelé par le symbole suivant dans la notice:

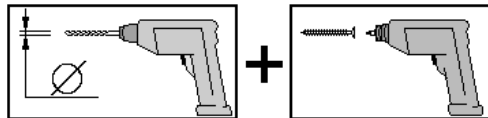

Consignes de montage sur la maison

Le local rapporté peut être monté à droite ou à gauche de la maison.

Le montage peut se faire en même temps que celui de la maison, mais aussi à tout moment ultérieur comme une extension.

Les poteaux peuvent être soit enterrés soit fixés dans une fondation en fonction de la nature du sous-sol.

Protection du bois

Cet article est en bois brut naturel. Il est impératif d'entretenir et de protéger le bois régulièrement. Veuillez vous renseigner auprès d'un spécialiste du bois pour connaître les traitements appropriés. Les mesures de protection du bois sont à effectuer par le client, sous sa propre responsabilité. Aucune garantie ne peut être accordée si le bois n'a pas été protégé selon les règles. Veuillez également vous reporter aux dispositions correspondantes de nos déclarations de garantie. Nous vous souhaitons beaucoup de plaisir à l'usage de votre article en bois.

Pour le montage, nous vous recommandons de préparer les outils suivants.

décamètre
à ruban

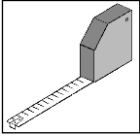

erceuse

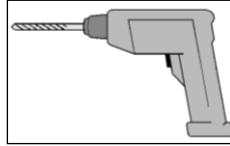

visseuse
électrique

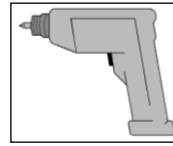

scie à denture fine/
scie circulaire



couteau universel

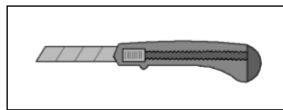

marteau



- | -

**Egredi clienti,
ci congratuliamo con voi per avere scelto un prodotto.**

Prima del montaggio leggete con cura le presenti istruzioni al fine di evitare errori di montaggio o danni.

IMPORTANTE !

Controllate subito con l'ausilio della lista di imballaggio che il prodotto sia stato fornito completo e senza danni.

Vi preghiamo di conservare la lista di imballaggio solo alla scadenza del periodo di garanzia. Questa lista serve per controllare la completezza della fornitura e deve essere conservata insieme allo scontrino. Con l'ausilio della lista è possibile risolvere eventuali reclami. I numeri di posizione della lista di imballaggio non corrispondono con i numeri di posizione delle seguenti istruzioni di montaggio.

Raccomandiamo di eseguire il montaggio in 2 persone.

Per scongiurare eventuali incidenti tenere lontano i bambini dal luogo di montaggio.

Ci riserviamo di apportare modifiche ai fini del progresso tecnologico. Per tale motivo è possibile che nelle rappresentazioni vengano a crearsi lievi differenze.

Per evitare danni agli elementi in legno si raccomanda di preforare tutti i punti di avvitaggio a vite!

Il presente simbolo richiama la vostra attenzione su tale particolare nel corso delle istruzioni:

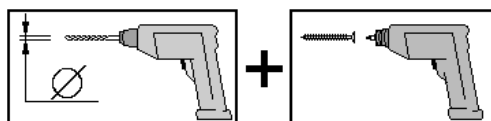

Indicazioni per il montaggio alla casa

Ogni armadio a montaggio esterno può essere installato a destra o a sinistra della casa.

Il montaggio può avvenire insieme a quello della casa, ma può avvenire anche successivamente come ampliamento.

I piloni possono essere interrati in base al terreno di fondo o fissati alle fondamenta.

Protezione legno

Il prodotto è composto dalla materia prima naturale del legno che rende le misure di protezione del legno assolutamente necessarie. Per il trattamento di protezione del legno a regola d'arte rivolgersi ad un esperto di protezione del legno.

Le misure di protezione del legno devono essere eseguite dal cliente sotto la sua responsabilità.

Senza protezione del legno prescritta non può essere assunta nessuna garanzia. Osservare anche le disposizioni al riguardo nelle nostre dichiarazioni di garanzia. Vi auguriamo un buon utilizzo del nostro prodotto legno.

Prima di iniziare con il montaggio tenere a portata di mano i seguenti utensili.

metro
a nastro

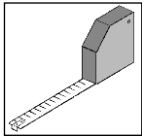

trapano

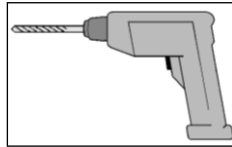

avvitatore
elettrico

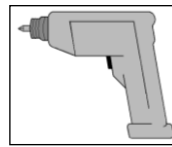

sega fine /
sega circolare portatile

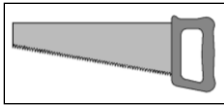

coltello universale

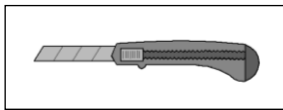

martello



- E -

Apreciado cliente:

Gracias por haber elegido un producto.

Lea de principio a fin estas instrucciones de montaje con el objeto de evitar errores o desperfectos.

¡IMPORTANTE!

Compruebe con la lista de embalaje si el producto ha llegado a sus manos completo e intacto.

No elimine la lista de embalaje antes de expirar el periodo de garantía. La lista sirve para controlar la integridad de las piezas y ha de guardarse junto con el comprobante de compra. Esta lista permite atender con éxito cualquier reclamación que pudiera surgir. Los números de artículo que figuran en la lista de embalaje no coincidan con los números especificados en las siguientes instrucciones de montaje.

Le aconsejamos realizar el montaje con 2 personas.

Para evitar accidentes, evite la presencia de niños en la cercanía inmediata durante el montaje.

Nos reservamos el derecho a realizar modificaciones acordes con el progreso técnico.

De ahí pueden surgir ligeras discrepancias en los dibujos y diagramas.

¡Por favor, haga previamente las perforaciones para todas las uniones atornilladas a fin de evitar daños en los elementos de madera!

El siguiente pictograma le recordará esta indicación durante el montaje:

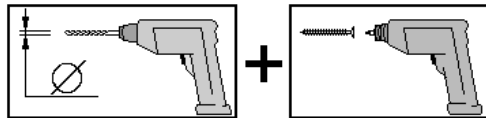

Instrucciones para el montaje en la casa

Cada armario puede montarse a la izquierda o la derecha de la casa.

El tejado puede montarse al mismo tiempo que la casa o también posteriormente como una ampliación de la misma.

Los postes pueden enterrarse, según el tipo de suelo, o fijarse a unos cimientos.

Preservación de la madera

El producto se compone de la materia prima natural madera. Esto hace que sea imprescindible tomar regularmente suficientes medidas de conservación de la madera. Para realizar un correcto tratamiento de conservación de la madera, póngase en contacto con un experto en conservación de maderas.

Las medidas de conservación de la madera las debe realizar el cliente bajo su responsabilidad.

Sin una conservación de la madera según prescripción, no se puede asumir ninguna garantía.

También tenga en cuenta las disposiciones que figuran en nuestra declaración de garantía a este respecto.

Le deseamos que disfrute de su producto de madera.

Antes de emprender el montaje hay que tener a mano las siguientes herramientas.

Cintra métrica
enrollable /
Cinta métrica

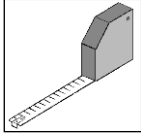

Taladradora
eléctrica

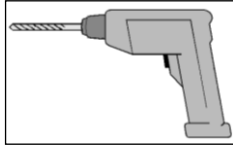

Destornillador
léctrico

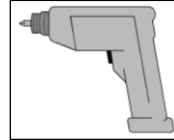

Sierra fina /
Sierra circular de mano

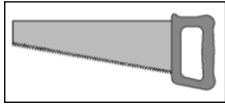

Cuchilla universal

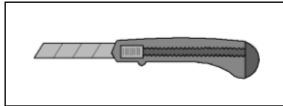

Martillo



- P -

Estimada(o) Cliente,

Parabéns por ter escolhido um produto!

Antes de proceder à montagem, leia o presente manual de instruções na íntegra, por forma a evitar erros de montagem ou danos.

IMPORTANTE !

Com base na lista da embalagem, verifique de imediato se o produto está completo e se não apresenta danos.

Conserve a lista da embalagem até o período de garantia expirar. Esta lista serve para verificar se as peças se encontram completas e deverá ser guardada juntamente com o comprovativo da compra. Esta lista permite ainda a resolução imediata de eventuais reclamações. As posições da lista da embalagem não coincidem com as posições das seguintes instruções de montagem.

Recomendamos que a montagem seja efectuada por duas pessoas.

Com vista à prevenção de acidentes, há que evitar a presença de crianças nas proximidades do local de montagem.

Reservamo-nos o direito a alterações decorrentes de avanços tecnológicos, na sequência dos quais os desenhos poderão apresentar diferenças não muito significativas.

Fure previamente todas as uniões roscadas por forma a evitar danos nas peças de madeira! Ao longo do presente manual de instruções, o seguinte símbolo chamará a sua atenção para esta necessidade:

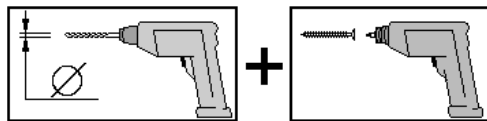

Instruções relativas à montagem na casa

Cada armário amovível pode ser montado do lado esquerdo ou direito da casa.

A montagem pode ser efectuada simultaneamente com a da casa ou em qualquer altura posterior como ampliação.

Conforme a base, o poste pode ser cravado no solo ou fixado a uma fundação.

Protecção da madeira

O produto é composto por matéria-prima natural, neste caso, a madeira. Isto torna obrigatoriamente necessário que sejam tomadas com regularidade medidas de preservação da madeira. Para um tratamento adequado de preservação da madeira, dirija-se a um especialista da área.

A tomada de medidas de preservação da madeira é da responsabilidade do cliente. Não é concedida garantia no caso de não ser efectuada uma preservação da madeira de acordo com as medidas regulamentadas. Tenha também em atenção as nossas condições de garantia a este respeito.

Esperamos que se divirta com o seu produto de madeira.

Antes de dar início à montagem, deverá ter à mão as seguintes ferramentas.

Fita métrica com /
sem enrolador

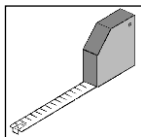

Berbequim

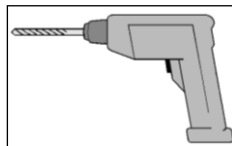

Aparafusadora
eléctrica

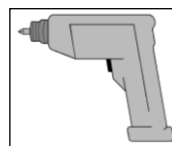

Serra fina /
Serra circular manual

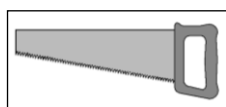



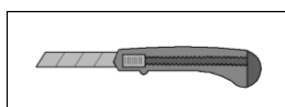

Lâmina universal

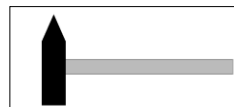



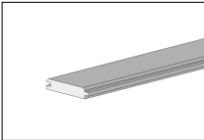

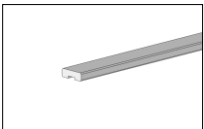
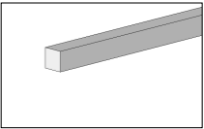
Martelo

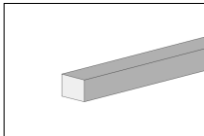

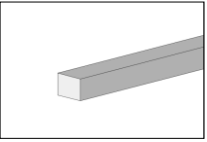
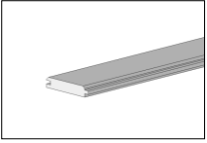
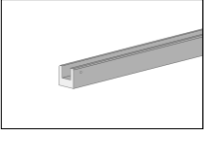
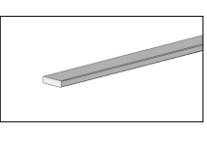
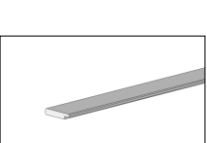
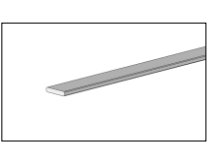



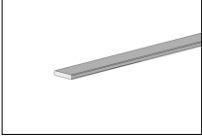
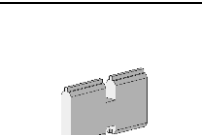
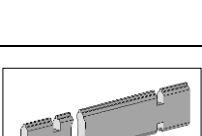
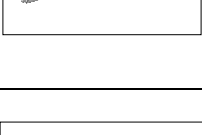
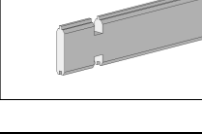
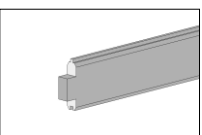
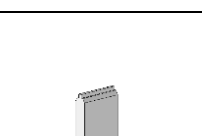



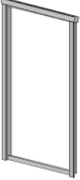





D	Stückliste		
GB	Parts list	E	Lista de piezas
F	liste des pièces	P	Lista de peças
I	lista pezzi		

Pos	Bild	Land	Benennung	Abmessung [mm]	Anzahl [Stück]		
					100.0401	100.0402	100.0403
①		D	Dachschalung	18,5 / 96 / 580	27	38	47
		GB	roof boarding				
		F	sous-toiture				
		I	soffitta				
		E	Entarimado cubierta				
		P	telhado				
②		D	Windfeder	18,5 / 146 / 600	2	2	2
		GB	Bargeboard				
		F	ressort pare-vent				
		I	molla a vento				
		E	Lengüeta cortavientos				
		P	Tábua pára-vento				
③		D	Windfederabdeckung	18,5 / 58 / 600	2	2	2
		GB	Bargeboard cover				
		F	recouvrement ressort pare-vent				
		I	copertura molla a vento				
		E	Cubierta lengüeta cortavientos				
		P	Cobertura da táboa pára-vento				
④		D	Pfosten	58 / 58 / 1900	1	1	1
		GB	Stud				
		F	poteau				
		I	montante				
		E	Poste				
		P	Poste				
⑤		D	Kopfband	58 / 58 / 500	1	1	1
		GB	Strut				
		F	bande de tête				
		I	nastro terminale				
		E	Cabecero				
		P	Contrafixa				
⑥		D	Bodenbalken	45 / 70 / 1400	2	2	2
		GB	Floor beam				
		F	solive				
		I	traversa del pavimento				
		E	Viguetas del piso				
		P	Barrote de soalho				

Pos	Bild	Land	Benennung	Abmessung [mm]	Anzahl [Stück]		
					100.0401	100.0402	100.0403
7		D	Bodenbalken	45 / 70 / 765	3	3	3
		GB	Floor beam				
		F	solive				
		I	traversa del pavimento				
		E	Viguetas del piso				
		P	Barrote de soalho				
8		D	Bodendiele	18,5 / 96 / 1160	8	8	8
		GB	Board				
		F	planche de sol				
		I	tavola, pavimento notte				
		E	Tabla, ático-dormitorio				
		P	Tábua, sobrado				
9		D	Anschlußleiste	50 / 50 / 1920	2	2	2
		GB	Connecting batten				
		F	barrette de raccordement				
		I	morsettiera, barra di collegamento				
		E	Regleta de contactos				
		P	Régua de conexão				
10		D	Pfette	18,5 / 96 / 1850 18,5/96/1540	2	-	2
		GB	Purlin				
		F	panne				
		I	arcareccio				
		E	Cabio				
		P	Caibro; Madre				
11		D	Traubrett	18,5 / 96 / 2300 18,5 / 96 / 2300	1	-	2
		GB	Fascia board				
		F	frise				
		I	asse di gronda				
		E	Alero				
		P	Tábua de beiral				
12		D	Unterschlagleiste	18,5 / 96 / 2300 18,5 / 96 / 1994	1	-	4
		GB	Impact batten				
		F	battement				
		I	listello di battuta				
		E	Batiente				
		P	Sanefa				
13		D	Seitenblende	18,5 / 146 / 600	4	4	4
		GB	Cover				
		F	cache				
		I	pannello di copertura				
		E	Protección				
		P	Anteparo				

Pos	Bild	Land	Benennung	Abmessung [mm]	Anzahl [Stück]		
					100.0401	100.0402	100.0403
14		D	Schlagleiste	11 / 58 / 1650	2	2	2
		GB	Impact batten				
		F	battement				
		I	listello di battuta				
		E	Batiente				
		P	Sanefa				
15		D	Wandbohle	28 / 121 / 228	30	30	30
		GB	Wall board				
		F	madrier de paroi				
		I	tavola da parete				
		E	Tablón de pared				
		P	Prancha de parede				
16		D	Wandbohle	28 / 121 / 1420	1	1	1
		GB	Wall board				
		F	madrier de paroi				
		I	tavola da parete				
		E	Tablón de pared				
		P	Prancha de parede				
17		D	Wandbohle	28 / 121 / 730	30	30	30
		GB	Wall board				
		F	madrier de paroi				
		I	tavola da parete				
		E	Tablón de pared				
		P	Prancha de parede				
18		D	Wandbohle	28 / 121 / 630	2	2	2
		GB	Wall board				
		F	madrier de paroi				
		I	tavola da parete				
		E	Tablón de pared				
		P	Prancha de parede				
19		D	Wandbohle	28 / 121 / 100	2	2	2
		GB	Wall board				
		F	madrier de paroi				
		I	tavola da parete				
		E	Tablón de pared				
		P	Prancha de parede				
20		D	Wandbohle	28 / 54 / 1420	1	1	1
		GB	Wall board				
		F	madrier de paroi				
		I	tavola da parete				
		E	Tablón de pared				
		P	Prancha de parede				
21		D	Sockelbohle	28 / 63 / 730	2	2	2
		GB	Base board				
		F	madrier de socle				
		I	tavola di zoccolo				
		E	Tablón de zócalo				
		P	Prancha de base				

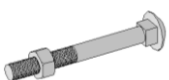
Pos	Bild	Land	Benennung	Abmessung [mm]	Anzahl [Stück]		
					100.0401	100.0402	100.0403
22		D	GR-Türrahmen	960 x 1675	1	1	1
		GB	Door frame				
		F	cadre de porte				
		I	telaio della porta				
		E	Marco de puerta				
		P	Caixilho da porta				
23		D	Türflügel, links	450 x 1650	1	1	1
		GB	Door leaf , left				
		F	vantail de porte, gauche				
		I	anta per porta, sinistro				
		E	Hoja de puerta , izquierda				
		P	Batente de porta, esquerda				
24		D	Türflügel, rechts	450 x 1650	1	1	1
		GB	Door leaf , right				
		F	vantail de porte, droite				
		I	anta per porta, destro				
		E	Hoja de puerta , derecha				
		P	Batente de porta, direita				
25	-			-	-	-	-
26		D	Schraube	5,0 x 120	22	22	22
		GB	Screw				
		F	vis				
		I	vite				
		E	Tornillo				
		P	Parafuso				
27		D	Schraube	5,0 x 80	6	6	6
		GB	Screw				
		F	vis				
		I	vite				
		E	Tornillo				
		P	Parafuso				
28		D	Schraube	6,0 x 50	25	25	25
		GB	Screw				
		F	vis				
		I	vite				
		E	Tornillo				
		P	Parafuso				
29		D	Schraube	4,0 x 60	22	22	22
		GB	Screw				
		F	vis				
		I	vite				
		E	Tornillo				
		P	Parafuso				

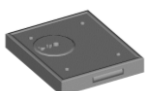
Pos	Bild	Land	Benennung	Abmessung [mm]	Anzahl [Stück]		
					100.0401	100.0402	100.0403
30		D	Schraube	4,0 x 40	20	20	20
		GB	Screw				
		F	vis				
		I	vite				
		E	Tornillo				
		P	Parafuso				
31		D	Schraube	3,5 x 35	340	340	340
		GB	Screw				
		F	vis				
		I	vite				
		E	Tornillo				
		P	Parafuso				
32		D	Halbrundkopfschraube	3,5 x 16	15	15	15
		GB	Round head screw				
		F	vis à tête bombée				
		I	vite a testa tonda				
		E	Tornillo de cabeza semiesférica				
		P	Parafuso de cabeça redonda cônica				
33		D	Dachpappstift	2,0 x 16	140	140	140
		GB	Tack				
		F	pointe pour carton bitumé				
		I	spina per cartone catramato				
		E	Espiga para cartón asfáltico				
		P	Prego de cabeça larga				
34		D	Kreuzgehänge	250 mm	4	4	4
		GB	Cross hanger				
		F	ferrure en croix				
		I	sospensione a crociera				
		E	Suspensión en cruz				
		P	Barra de união em T				
35		D	Schloßschraube	M6 x 60 M6 x 80	4 4	4 4	4 4
		GB	Carriage bolt				
		F	boulon à collet carré				
		I	vite con lucchetto				
		E	Tornillo de cabeza de lenteja y cuello				
		P	Parafuso de reigada quadrada				
36		D	Schubriegel mit Schließblech	5 x 100	2	2	2
		GB	Sash bolt with striking plate				
		F	verrou avec pièce de fermeture				
		I	catenaccio con bocchetta				
		E	Cerrojo con chapa de cierre				
		P	Fecho de correr com chapa de fecho				
37		D	Kastenschloß mit Schlüsselschild	100 x 86	1	1	1
		GB	Box lock with escutcheon				
		F	bloc serrure avec étiquette à clé				
		I	serratura a scatola con bocchetta				
		E	Cerradura de caja con escudo de bocallave				
		P	Cadeado em forma de caixa com espelho da fechadura				

Übersicht

GB	Overview
F	vue d'ensemble
I	panoramica
E	Vista general
P	Panoràmica



Abbildung 100.0402

Fußbodenmontage

GB	Floor assembly
F	montage du plancher
I	montaggio del pavimento
E	Montaje del piso
P	Montagem do piso

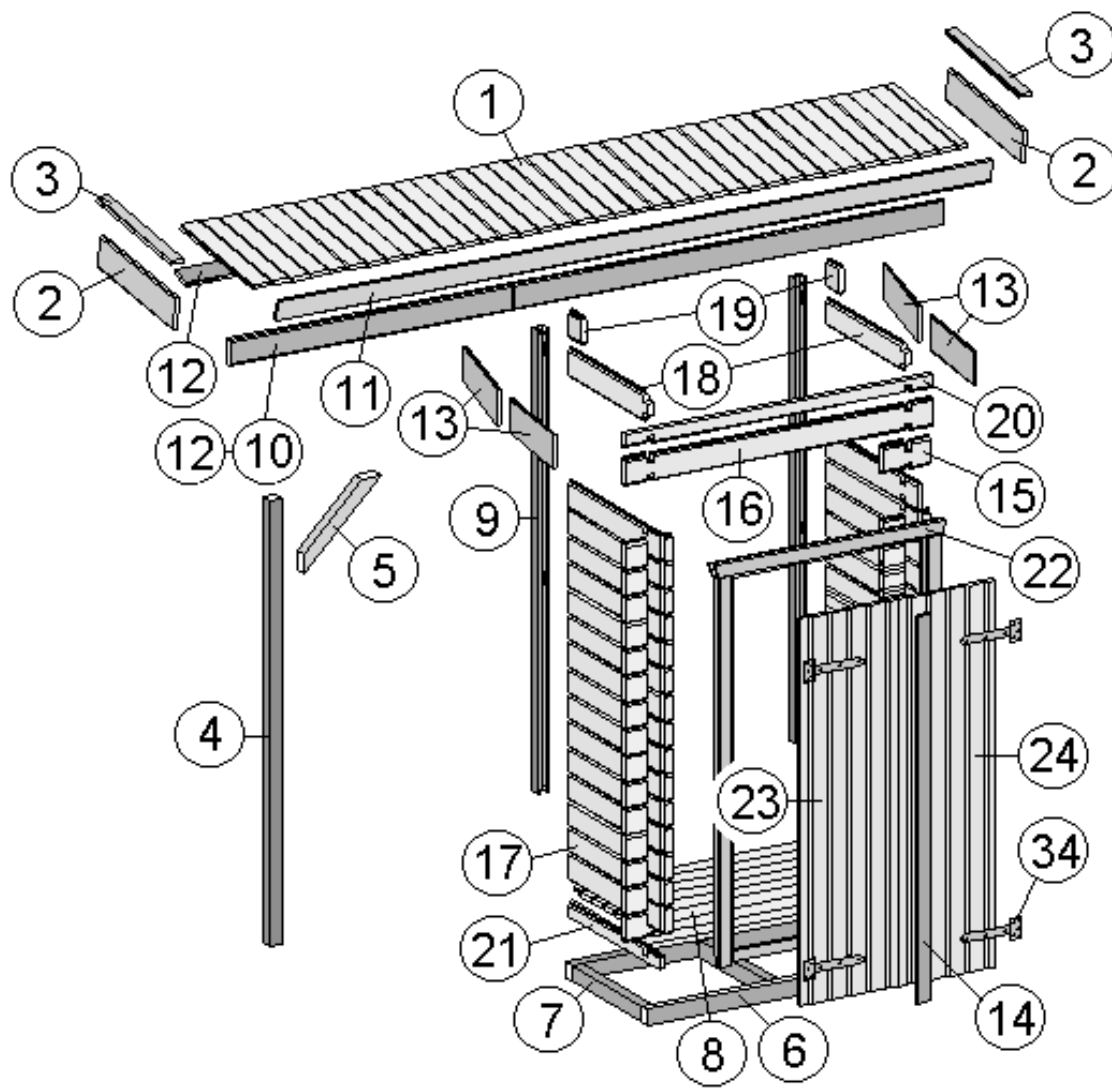
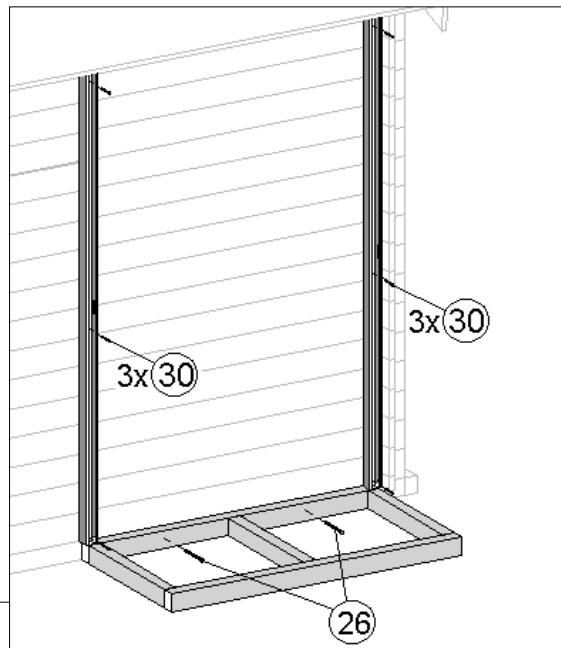
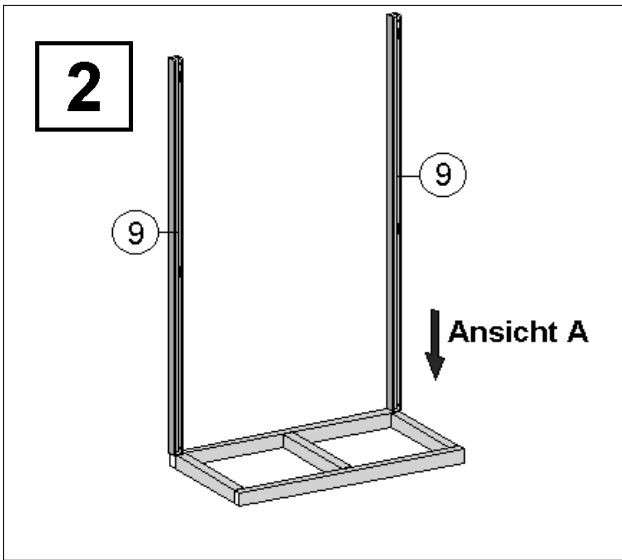
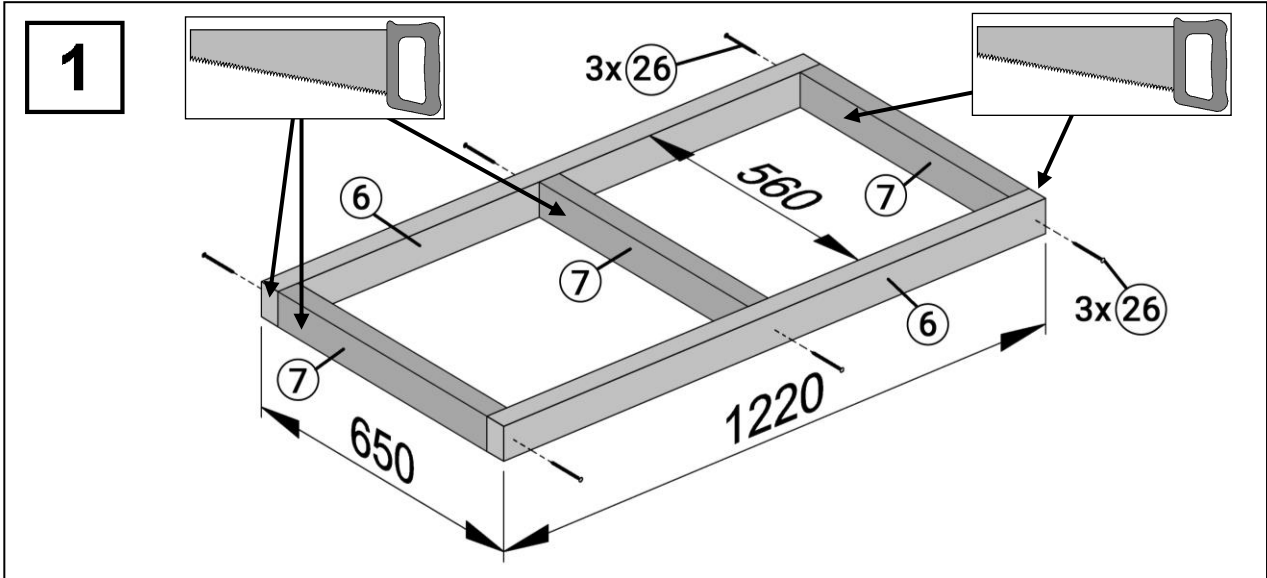
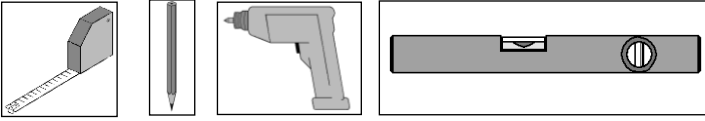

Ansicht A

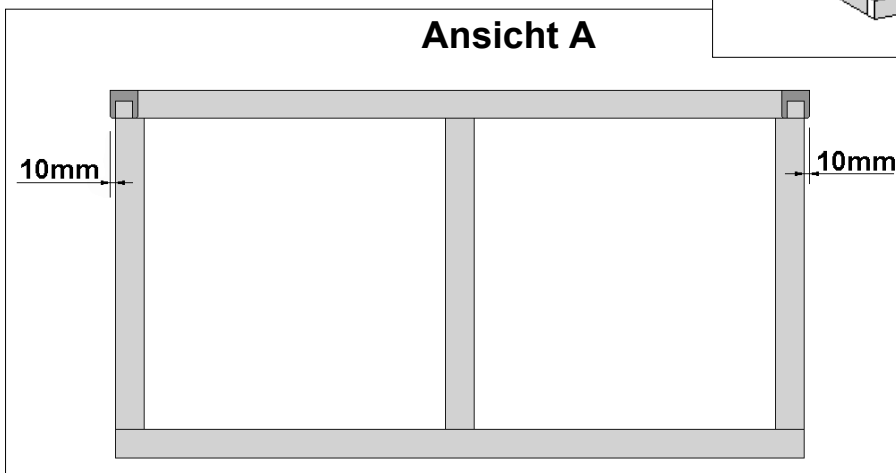

Wandaufbau

GB	Wall structure
F	montage de la paroi
I	struttura della parete
E	Montaje de la pared
P	Composição das paredes

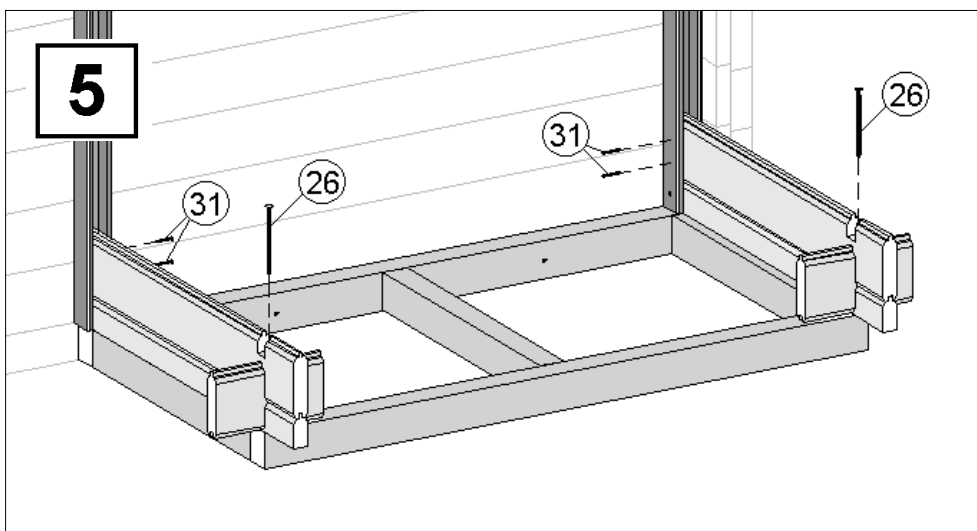
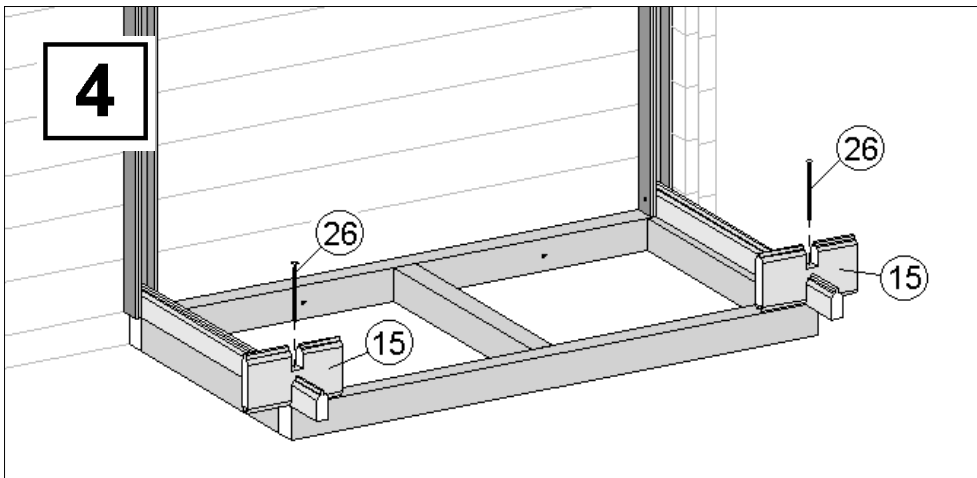
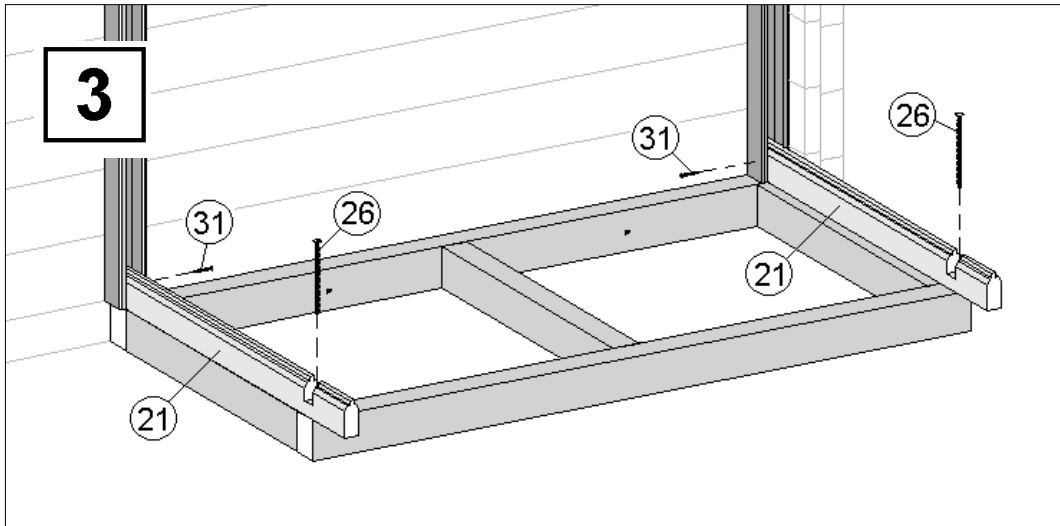
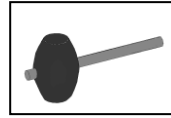
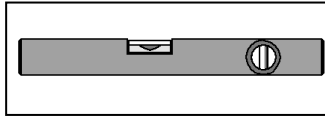
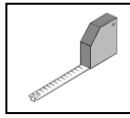
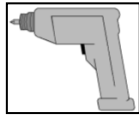
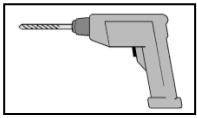

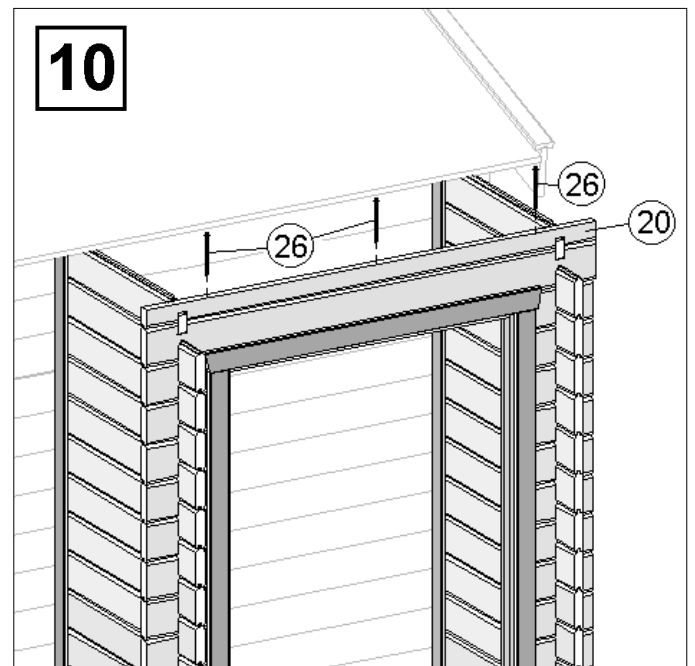
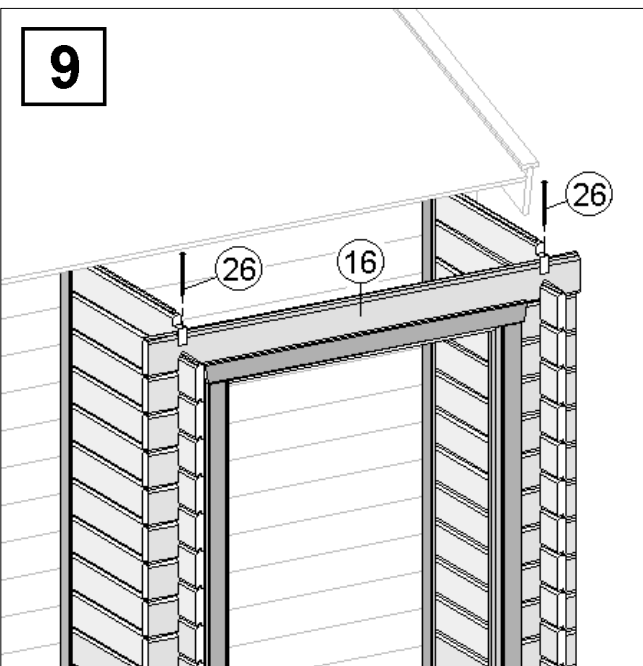
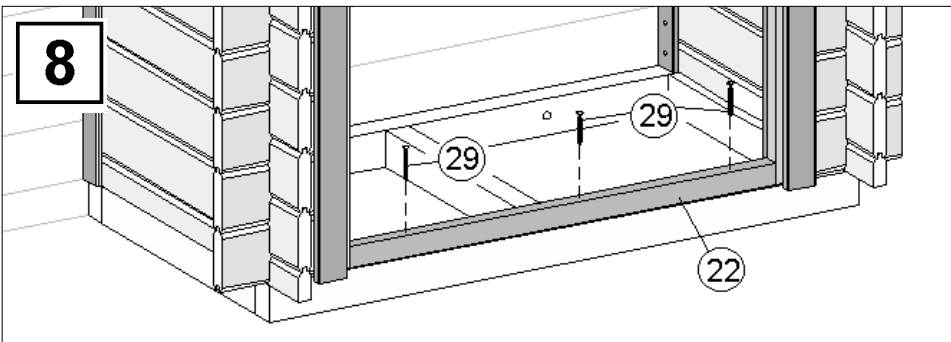
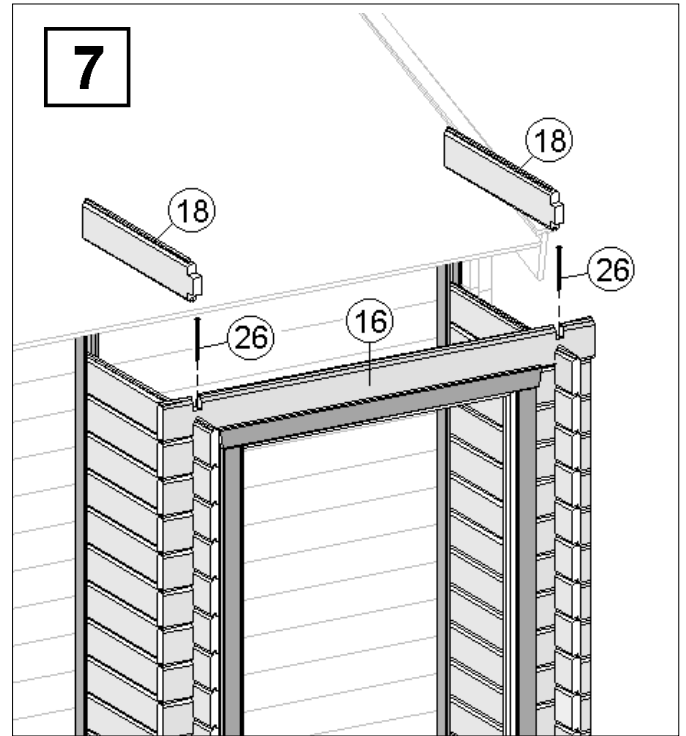
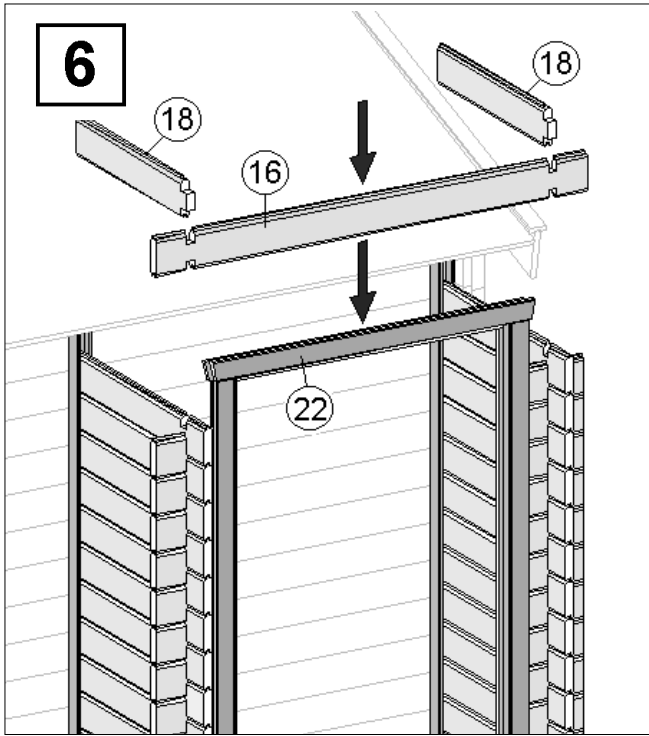
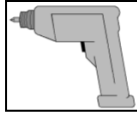
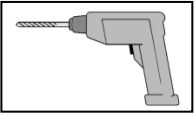

Pfosten/Pfette

GB	Stud	Purlin
F	poteau	panne
I	montante	arcareccio
E	Poste	Cabio
P	Poste	Caibro; Madre

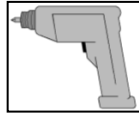
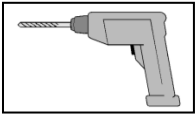

Art.-Nr.	L
100.0401	2300
100.0402	3300

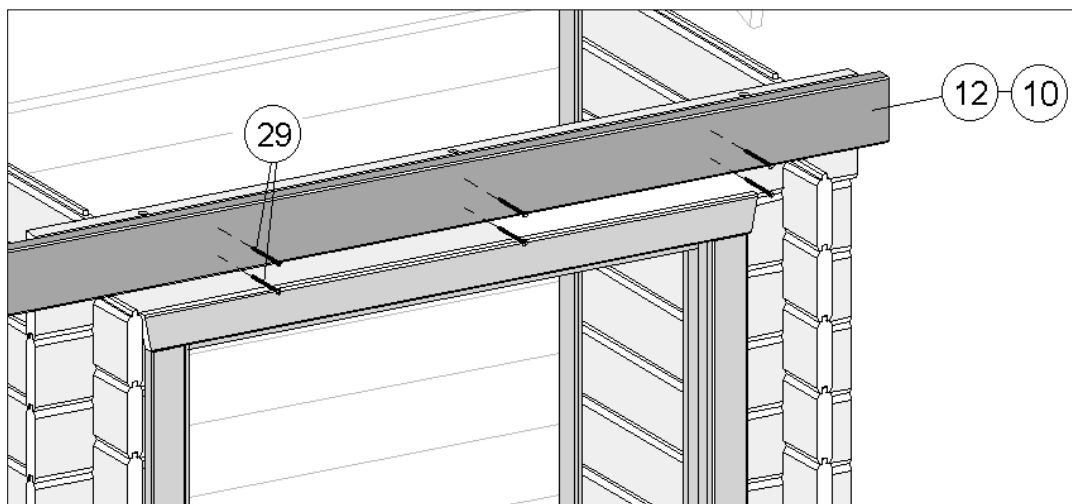
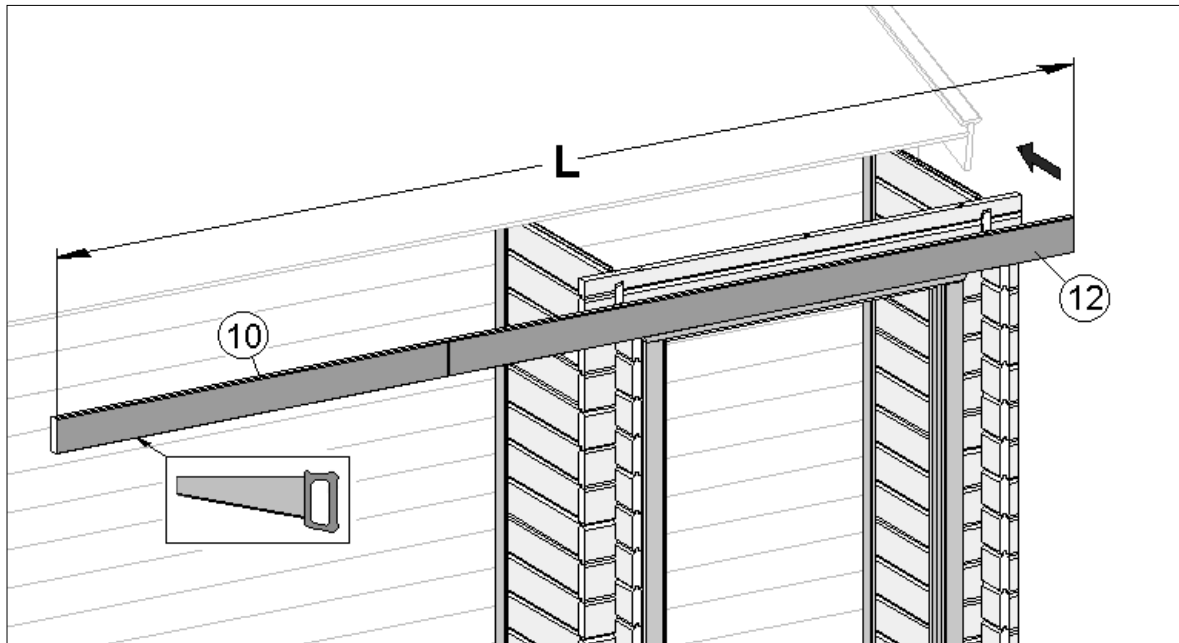
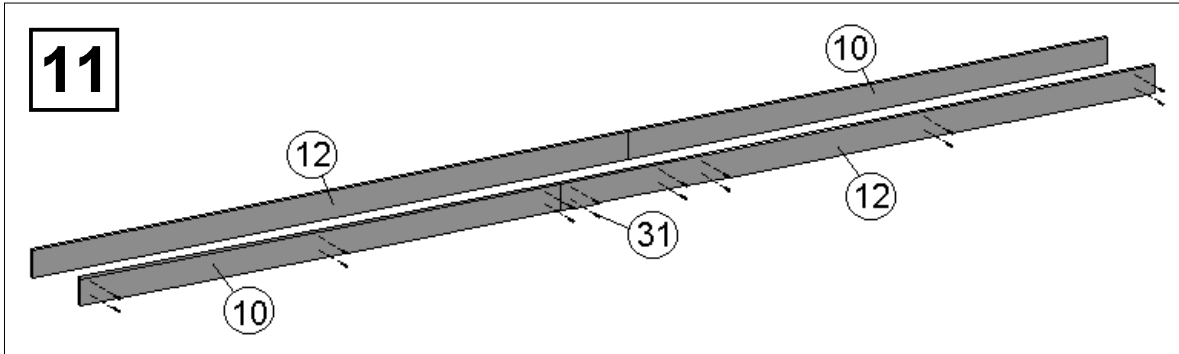

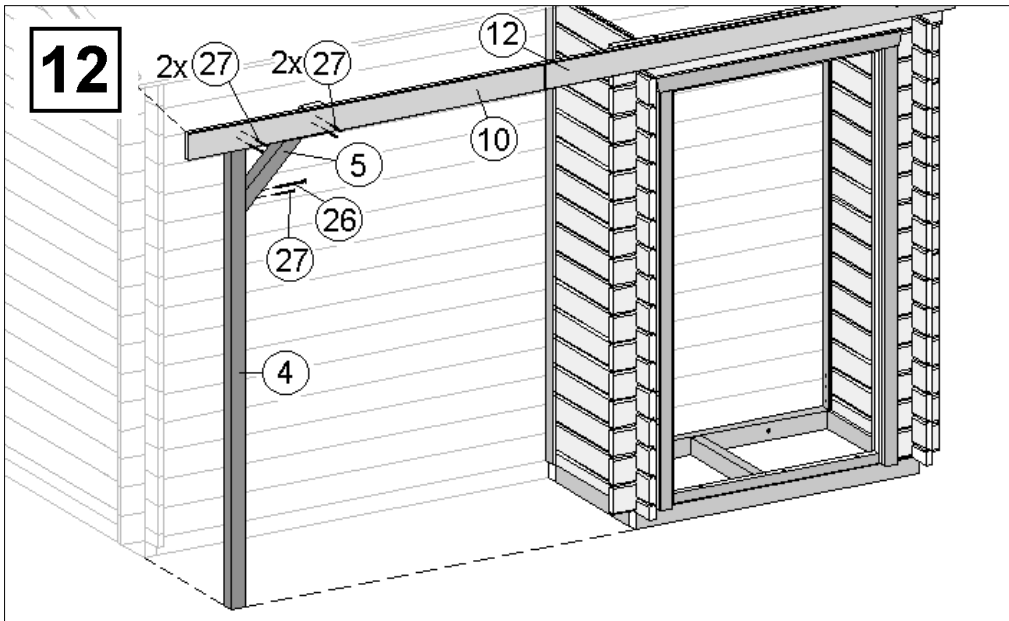

Bodendiele

GB	Board
F	planche de sol
I	tavola, pavimento notte
E	Tabla, ático-dormitorio
P	Tábua, sobrado

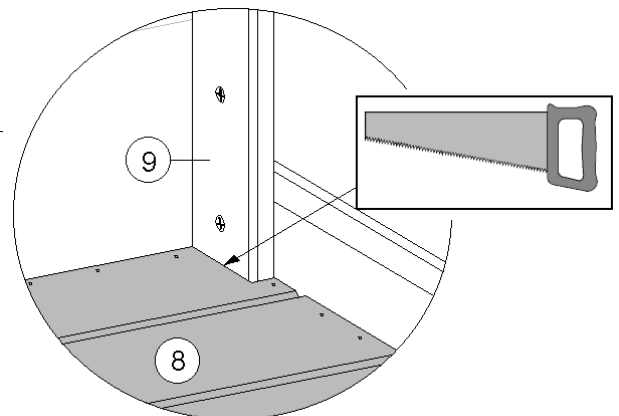
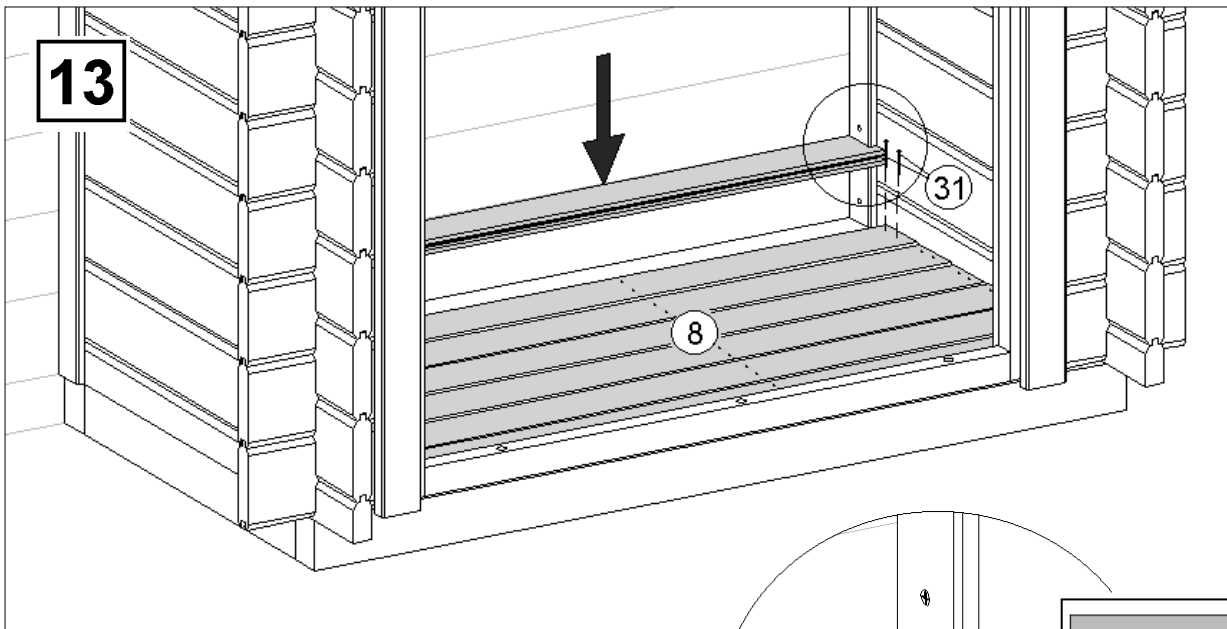
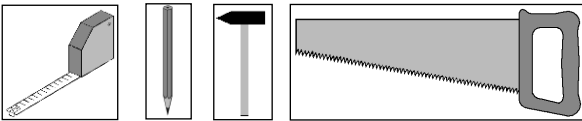

Dachmontage

GB	Roof assembly
F	montage du toit
I	montaggio del tetto
E	Montaje de la cubierta
P	Montagem do telhado

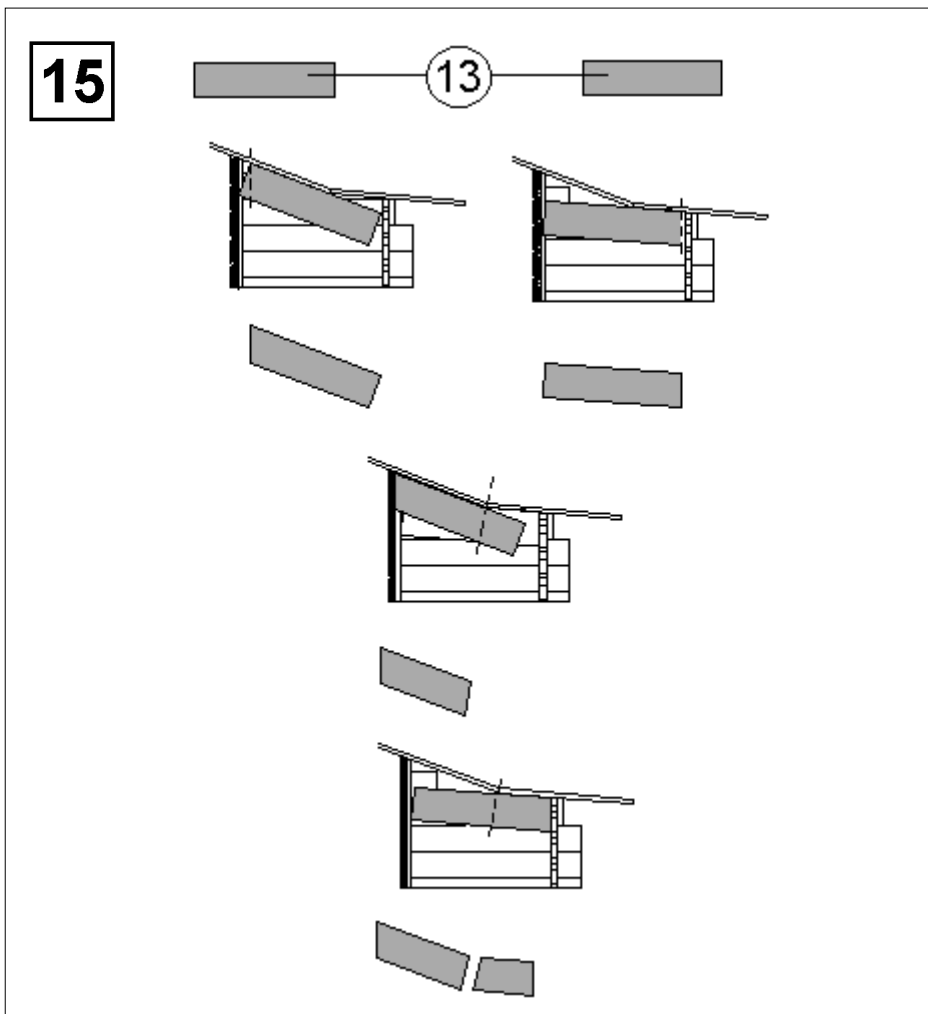
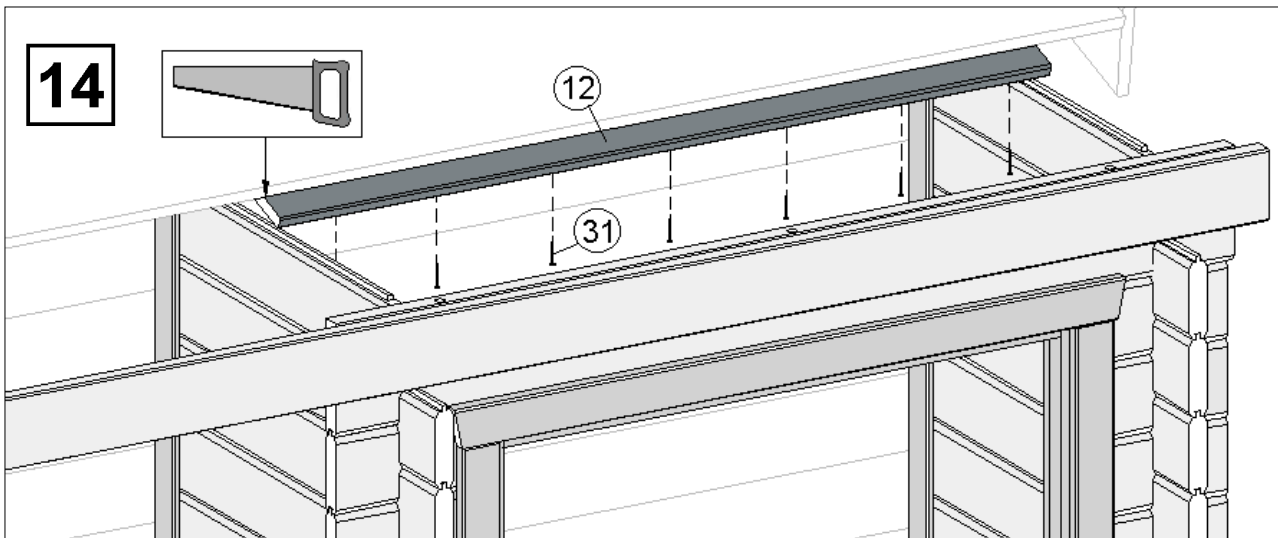
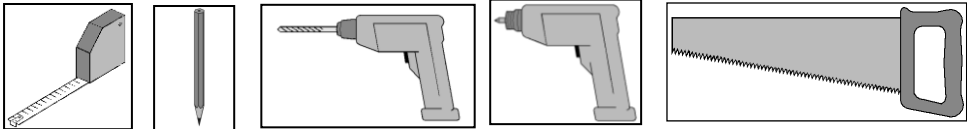
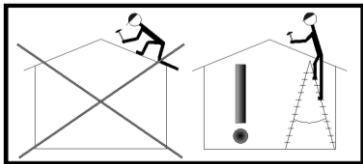

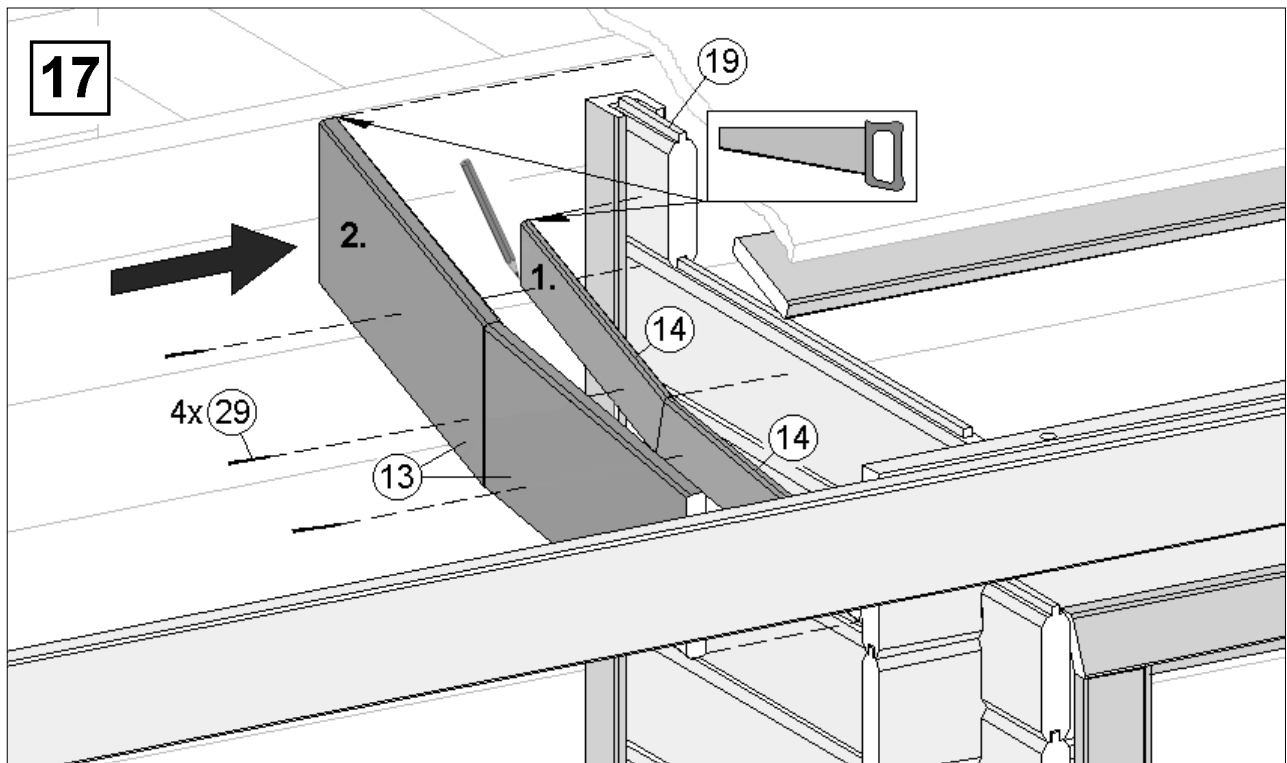
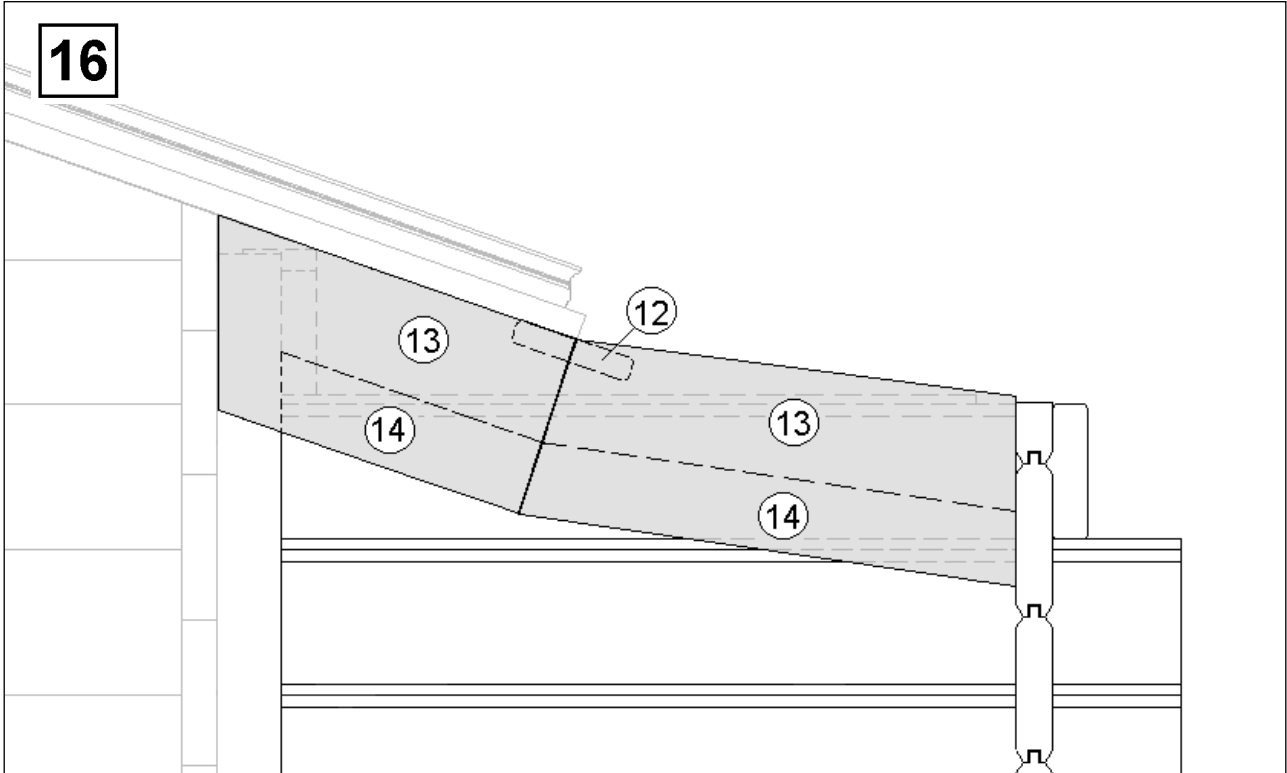
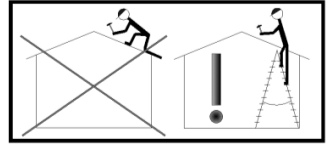
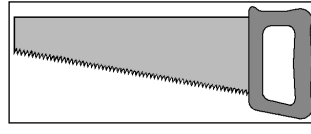
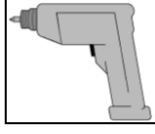
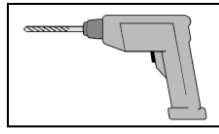
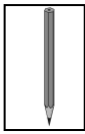
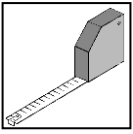

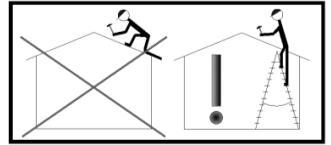
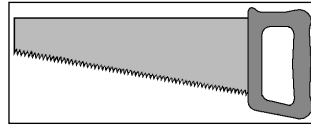
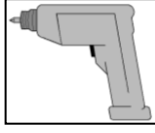
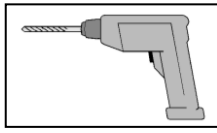
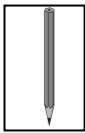
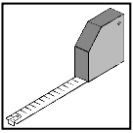

18

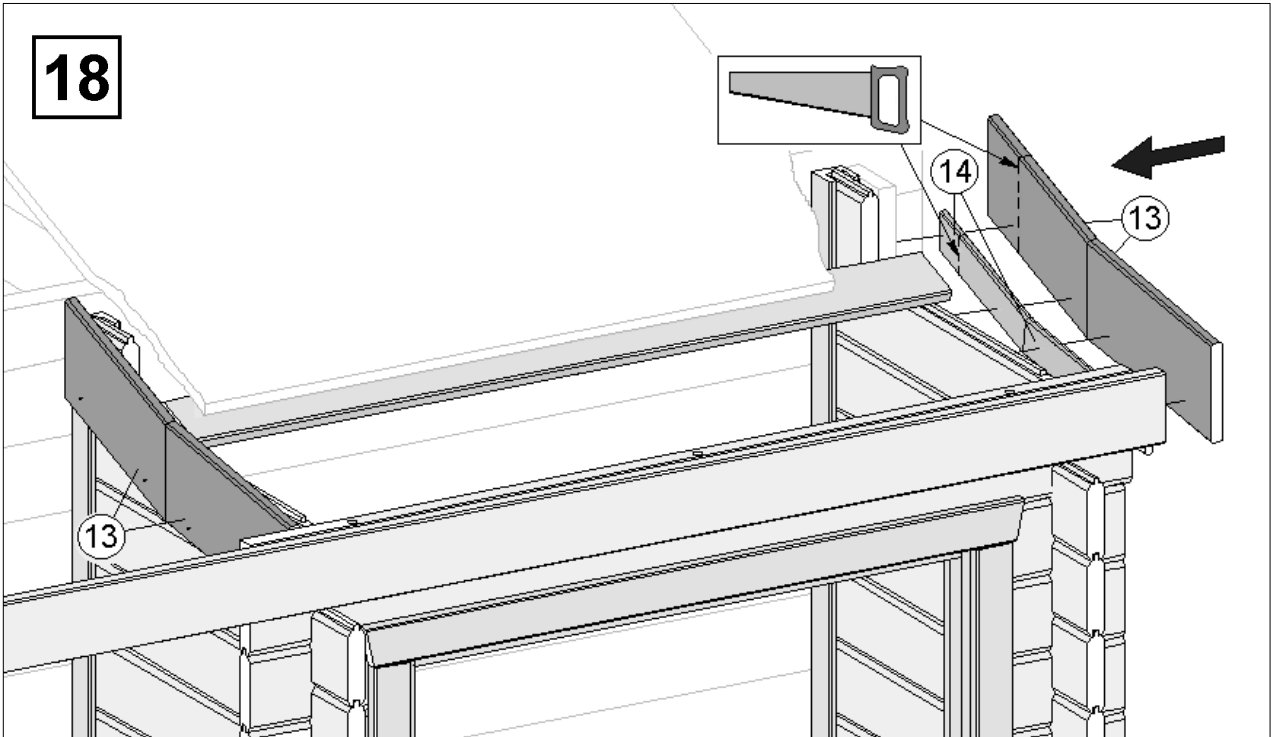

19

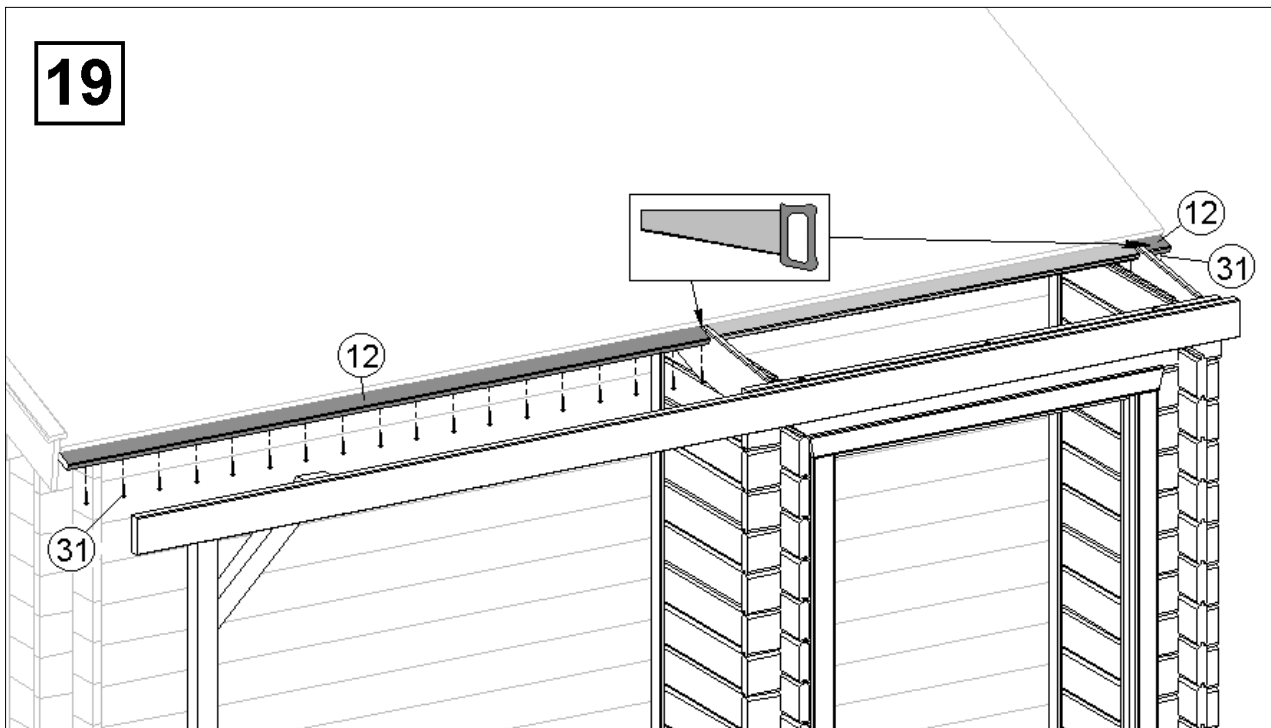

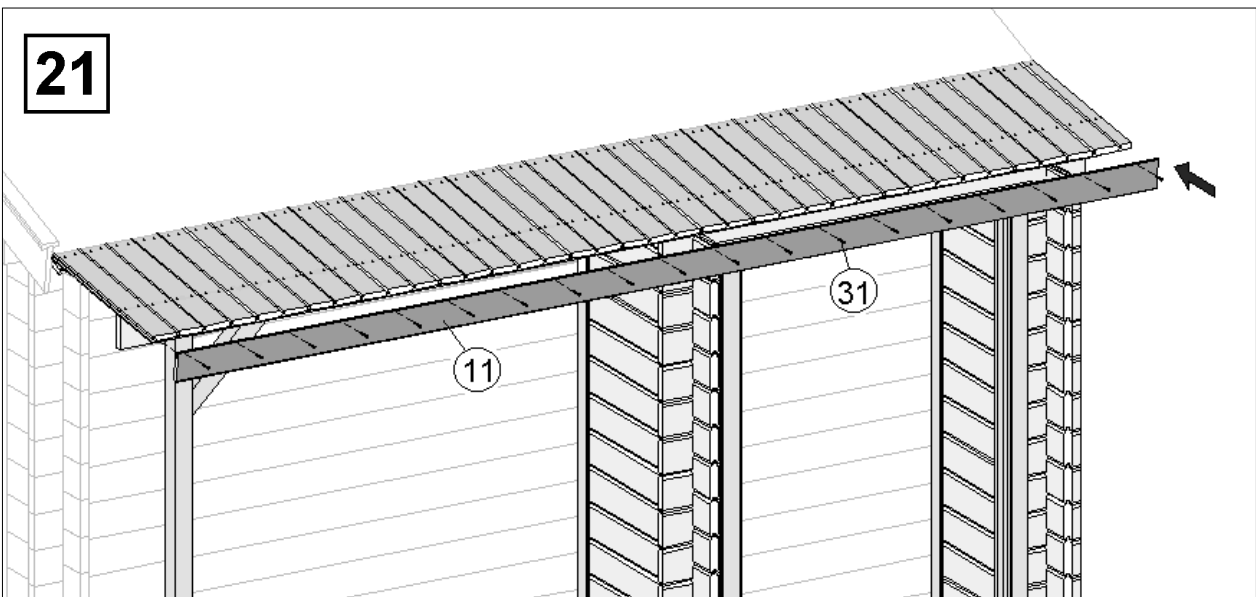
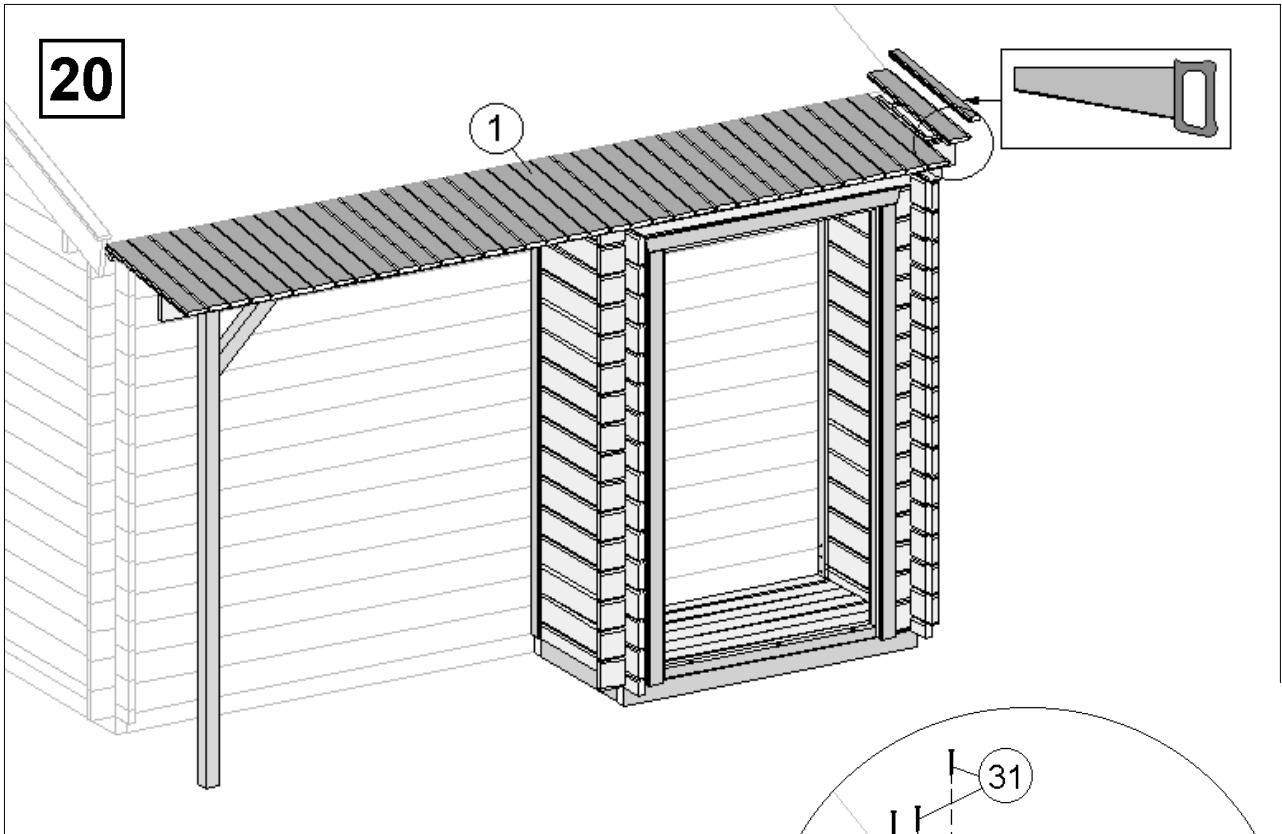

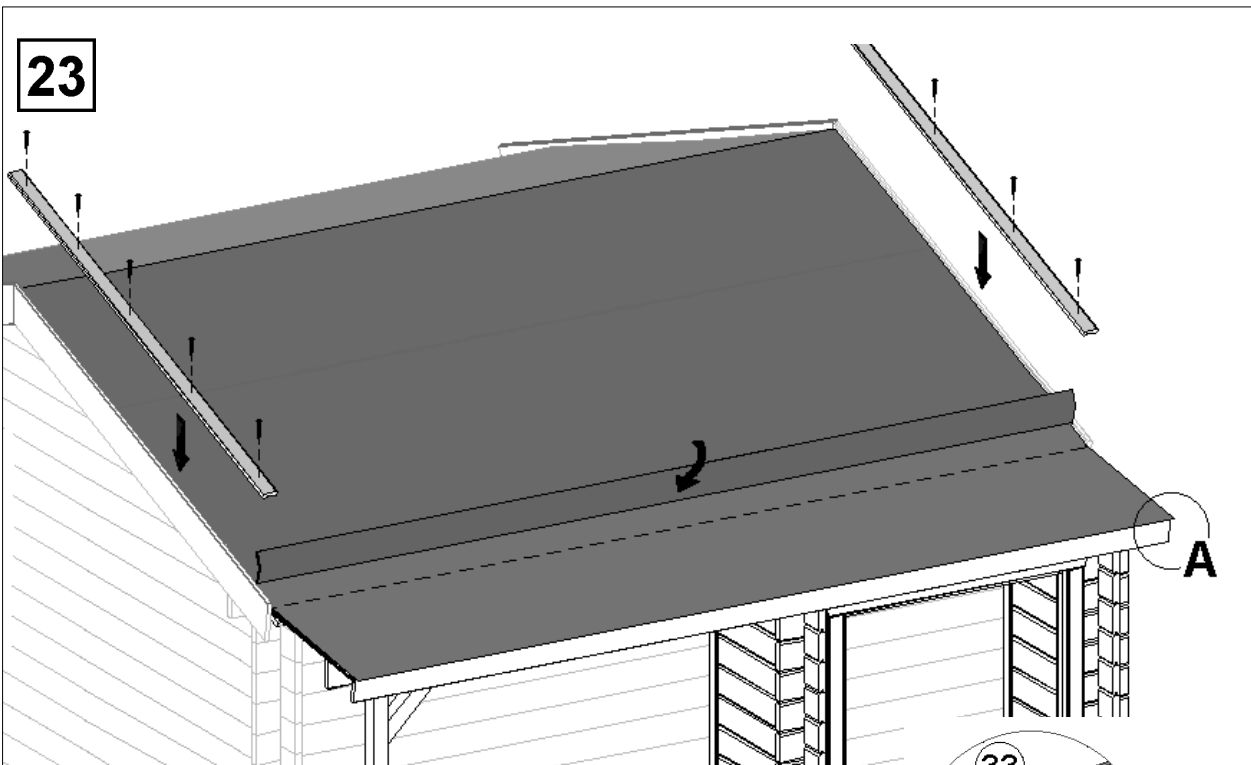
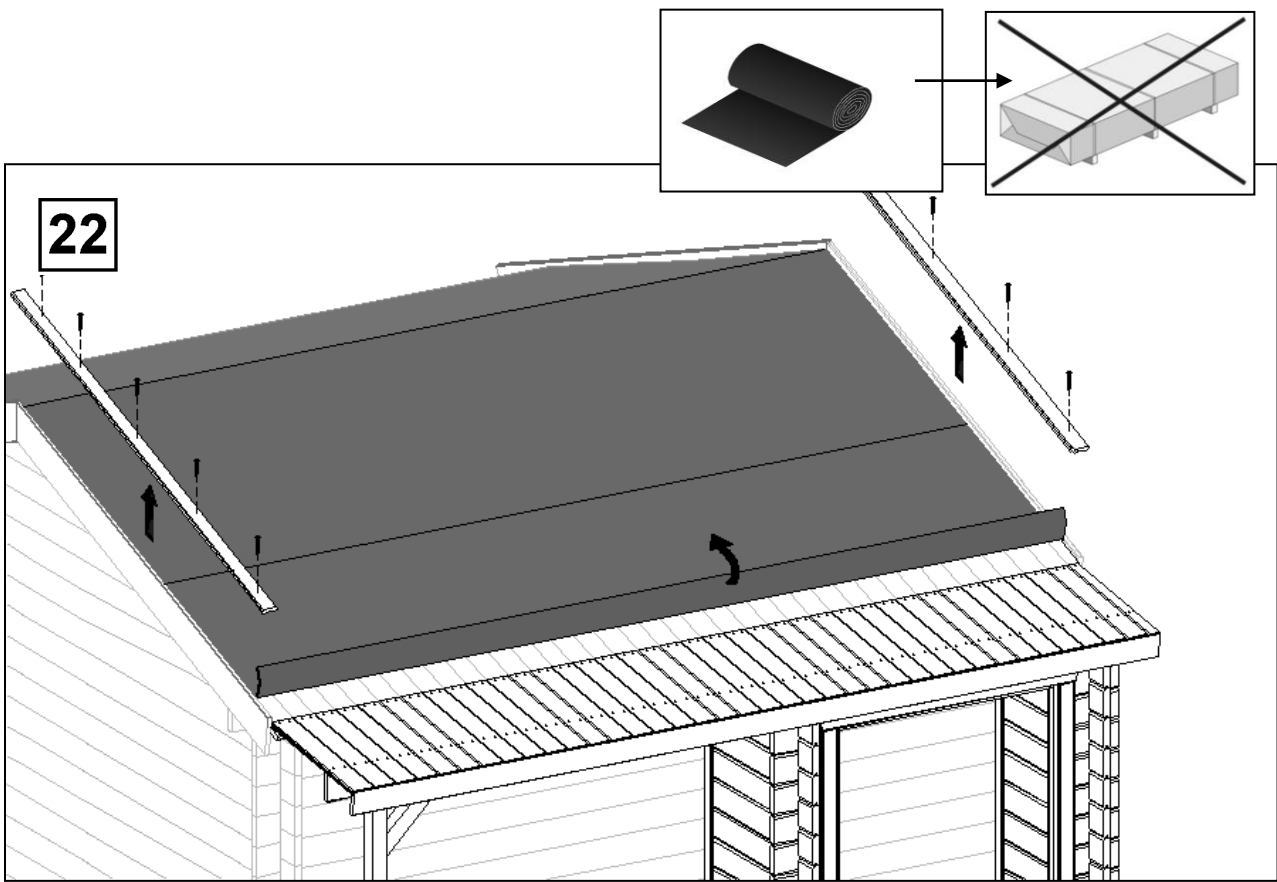

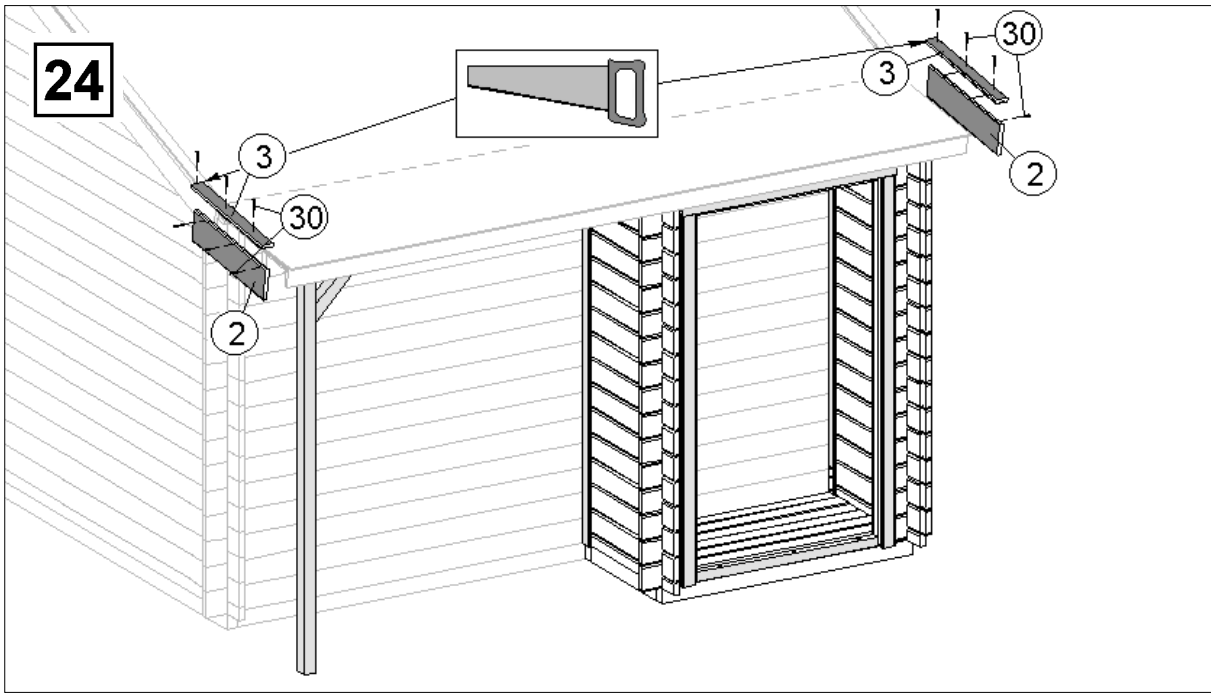

Türmontage

GB	Door assembly
F	montage de la porte
I	montaggio della porta
E	Montaje de puerta
P	Montagem da porta

D	außen
GB	outside
F	extérieur
I	esterno
E	exterior
P	exterior

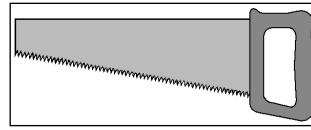
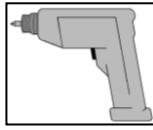
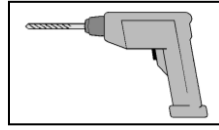

25

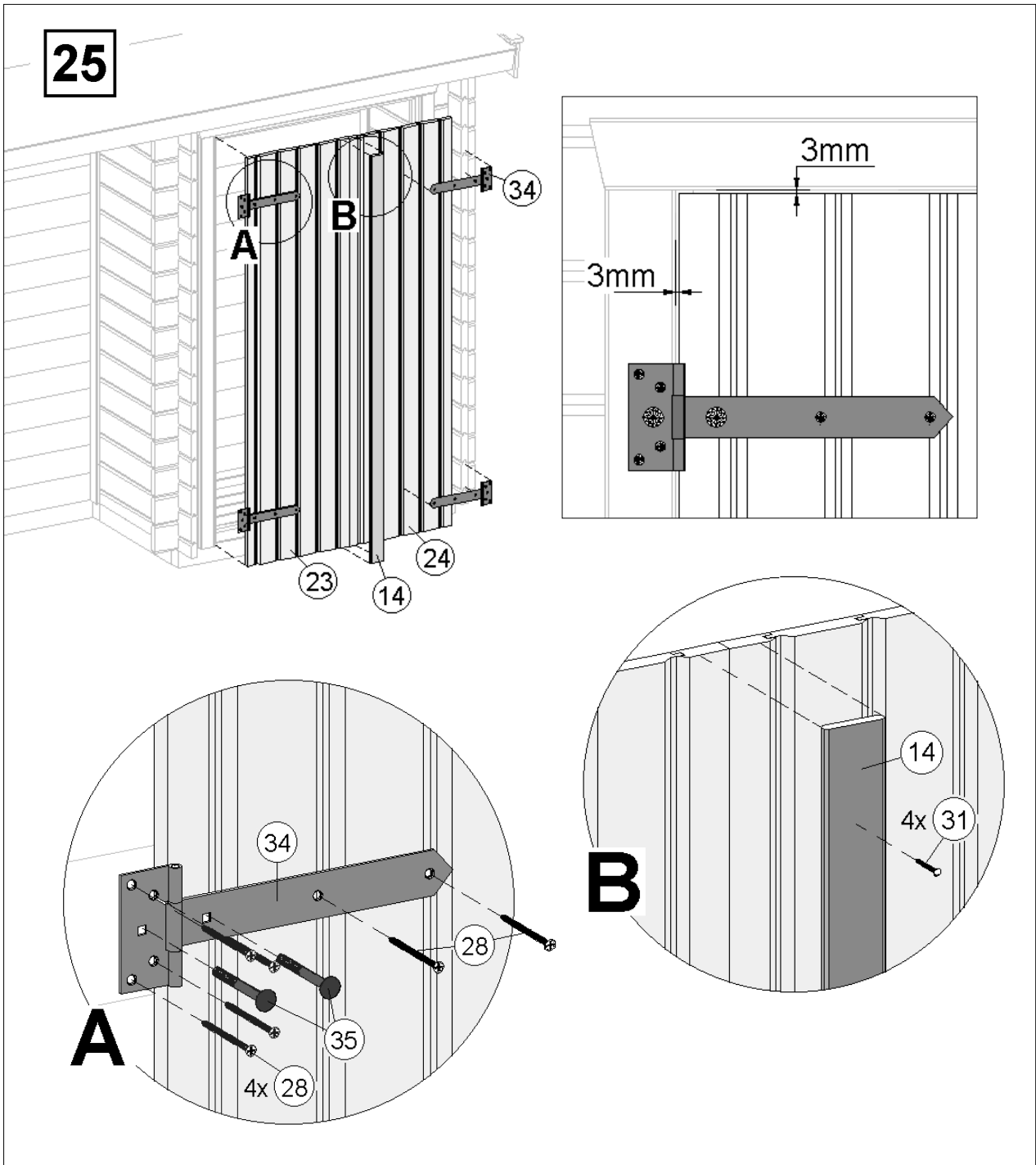

D	innen
GB	inside
F	intérieur
I	interno
E	interior
P	interior

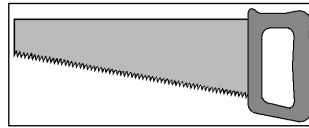
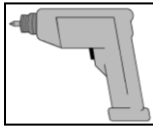
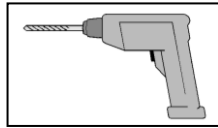

26

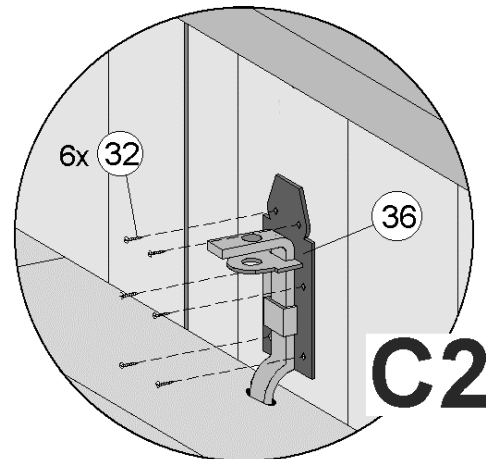
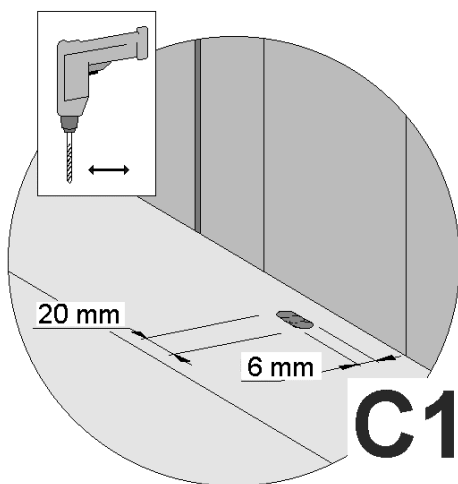
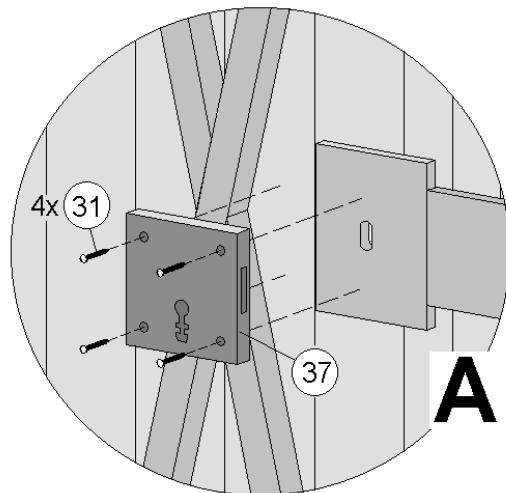
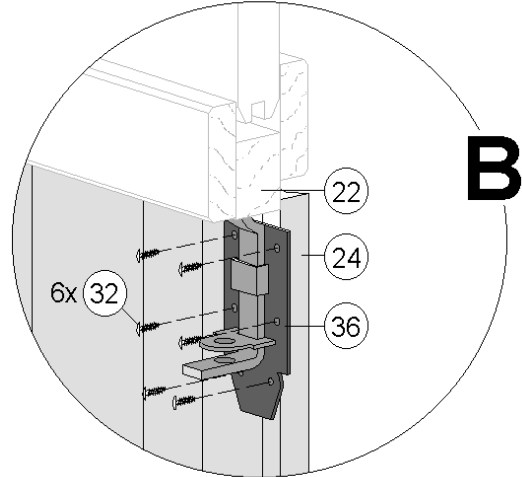
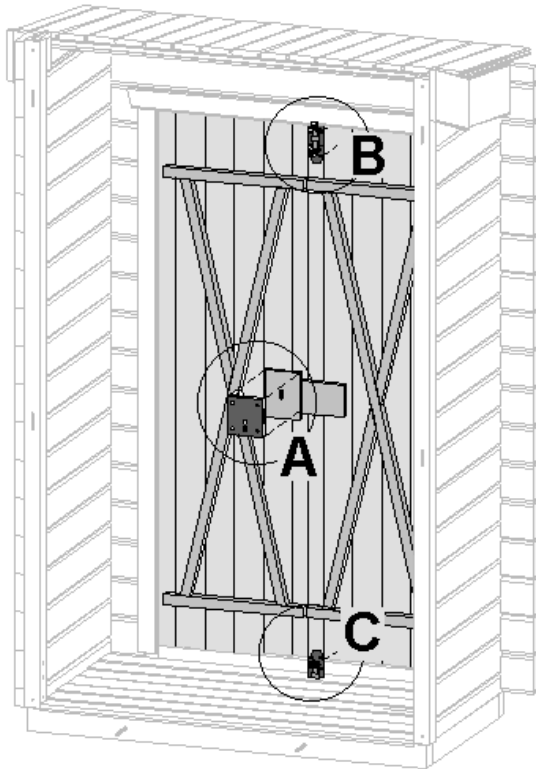

weka

MA Art.-Nr.: 800.0286.00.43