

Teil 1 Pure Garden

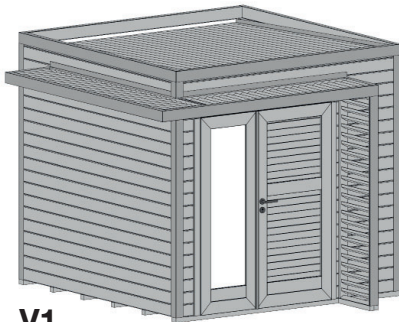

V1

Art.-Nr.: 417252540000
Art.-Nr.: 417252545000
Art.-Nr.: 417252545001
Art.-Nr.: 417252547000

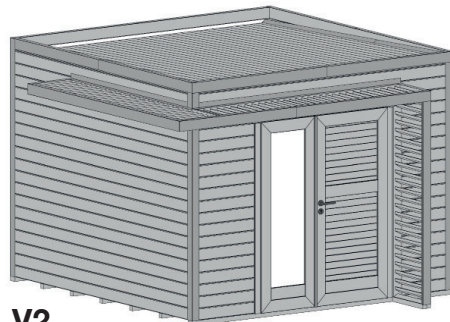

V2

Art.-Nr.: 417303040000
Art.-Nr.: 417303045000
Art.-Nr.: 417303045001
Art.-Nr.: 417303047001

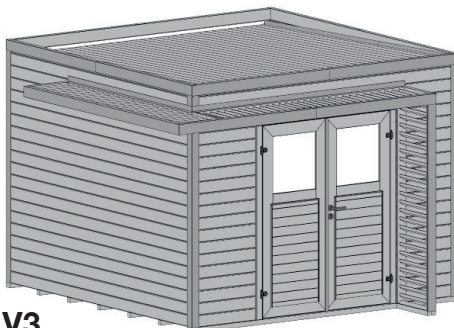

V3

Art.-Nr.: 417303040001
Art.-Nr.: 417303045002
Art.-Nr.: 417303045005
Art.-Nr.: 417303047002

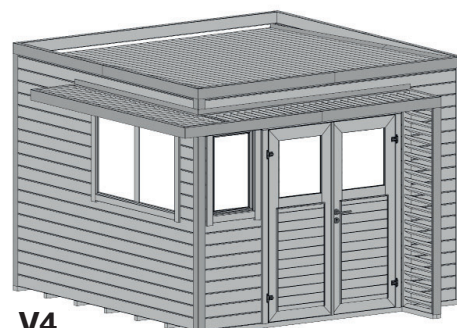

V4

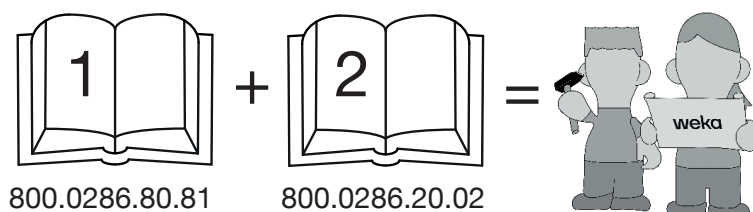

Art.-Nr.: 417303040002
Art.-Nr.: 417303045006
Art.-Nr.: 417303045007
Art.-Nr.: 417303047003

Montageanleitung





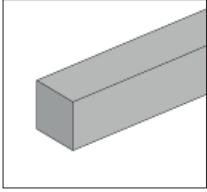

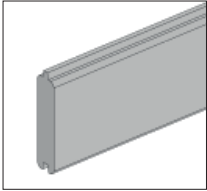
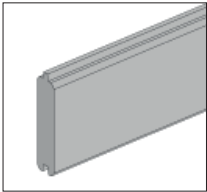
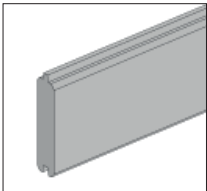
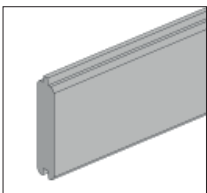
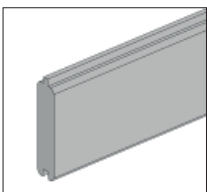
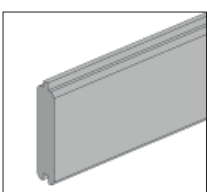

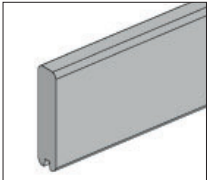
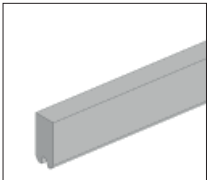
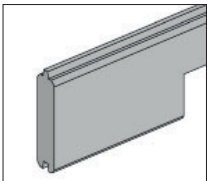
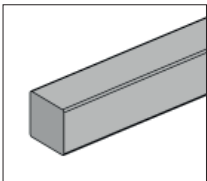
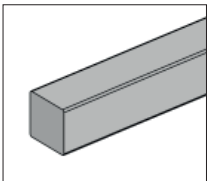
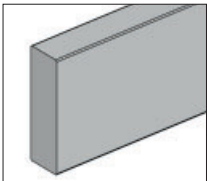
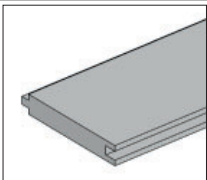
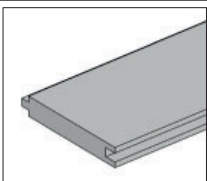
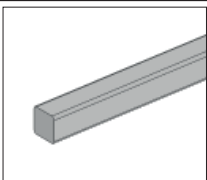
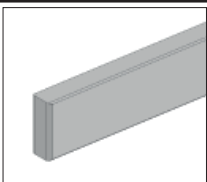

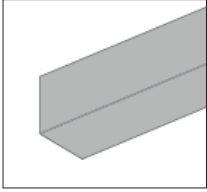
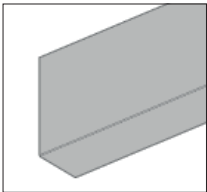
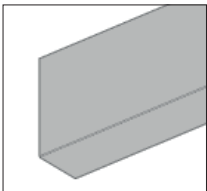
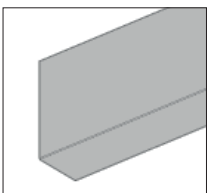
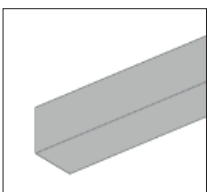
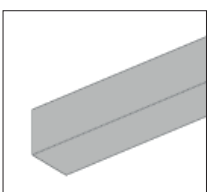
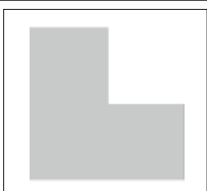
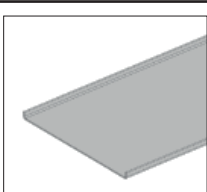
800.0286.80.81

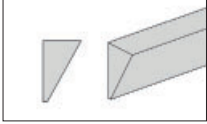
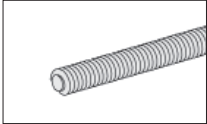









800.0286.20.02

Pos	Bild	Abmessung (mm)	Anzahl (Stück)			
			V1	V2	V3	V4
1	R004.3012.2490 R004.3012.2990 	45/45/2490 45/45/2990	6 -	- 7	- 7	- 7
2	G002.2003.014 	28/122/2970	-	-	-	1
3	RXXX.2003.2470 RXXX.2003.2970 	28/122/2470 28/122/2970	58 -	- 58	- 58	- 51
4	RXXX.2003.0725 RXXX.2003.0740 	28/122/725 28/122/740	- 16	16 -	16 -	16 -
5	RXXX.2003.0180 RXXX.2003.0705 	28/122/180 28/122/705	16 -	- 16	- 16	- 9
6	RXXX.2003.0295 	28/121/295	-	-	-	7
7	RXXX.2003.1275 	28/121/1275	-	-	-	7
8	RXXX.2003.0080 	28/121/80	-	-	-	7

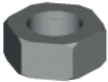

Pos	Bild	Abmessung (mm)	Anzahl (Stück)			
			V1	V2	V3	V4
9	RXXX.2012.2470 RXXX.2012.2970	 28/114/2470 28/114/2970	4 -	- 4	- 4	- 4
10	RXXX.2013.2470 RXXX.2013.2470	 28/57/2470 28/57/2970	1 -	- 1	- 1	- 1
11	GXXX.2003.011 GXXX.2003.012 GXXX.2003.013	 28/122/2470 28/122/2970 28/122/2970	1 - -	- 1 -	- 1 -	- - 1
12a	R002.3014.2060	 44/44/2060	2	2	2	2
12b	R002.3014.2100	 44/44/2100	2	2	2	2
13	R002.3005.2440 R002.3005.2940	 44/146/2440 44/146/2940	3 -	- 4	- 4	- 4
14	R002.2002.2435 R002.2002.2935	 15,5/98,5/2435 15,5/98,5/2935	28 -	- 33	- 33	- 33
15	R002.2002.2500 R002.2002.3000	 15,5/98,5/2500 15,5/98,5/3000	28 -	- 33	- 33	- 33
16	R002.3015.1870	 18/18/1870	7	8	8	9
17	G002.3019.001	 28/70/852	-	-	-	1





Pos	Bild	Abmessung (mm)	Anzahl (Stück)			
			V1	V2	V3	V4
18	FXXX.8001.2280 	80/80/2280	4	4	4	4
19	FXXX.8002.2500 	70/90/2500	5	1	1	1
20	FXXX.8002.0500 	70/90/500	2	2	2	2
21	FXXX.8002.2400 FXXX.8002.1550 	70/90/2400 70/90/1550	1 -	- 10	- 10	- 10
22	FXXX.8003.2400 FXXX.8003.1900 	60/60/2400 60/60/1900	- 1	1 -	1 -	1 -
23	FXXX.8003.2000 	60/60/2000	1	1	1	1
24	FXXX.8007.001 	120/120	1	1	1	1
25	FXXX.8004.1945 	14/92/1950	1	1	1	1













Pos	Bild	Abmessung (mm)	Anzahl (Stück)			
			V1	V2	V3	V4
26	R002.0850.1835 	28/45/1835	5	6	6	6
27	K009.6108.0001 	M8 x 610	3	3	3	3
28	BXXX.0406.0003 	90/500/1990	1	1	1	1
29	BXXX.0406.0005 	90/500/2500	1	1	1	1
30	BXXX.0406.0004 BXXX.0406.0006 	90/500/1900 90/500/2400	1 -	- 1	- 1	- 1
31	AXXX.0106.3001 		1	1	-	-
32	AXXX.0101.3001 		-	-	1	1
33	BXXX.0201.3001 		-	-	-	1
34	BXXX.0204.3001 		-	-	-	1

M417.002		Abmessung (mm)	Anzahl (Stück)
Pos	Bild		V1/2/3/4
M1	K001.6040.0004 	4,0 x 60	400
M2	K001.4040.0004 	4,0 x 40	30
M3	K010.5022.0001 	2,2 x 55	900
M4	K001.3035.0004 	3,5 x 30	60
M5	K002.1635.0004 	3,5 x 16	130
M6	K020.8400.0001 	Ø24	6
M7	K024.0800.0001 	M8	6
M8	K074.4513.0000 	45/137	6
M9	K100.1010.0006 K100.1010.0008  		1
M10	K004.9552.0006 	2,2 x 9,5	2

M100.122/123		Abmessung (mm)	Anzahl (Stück)
Pos	Bild		V1/2/3/4
M11	K012.2545.000X 	4,5 x 25	100

M100.032		Abmessung (mm)	Anzahl (Stück)
Pos	Bild		V4
(M12)	K046.2860.0006 		1
(M13)	K001.4040.0004 	4,0 x 40	8

M100.119		Abmessung (mm)	Anzahl (Stück)
Pos	Bild		V1/2
(M14)	K045.1460.0001 		1
(M15)	K050.5010.0001 	50/100	2
(M16)	K002.1635.0004 	3,5 x 16	20
(M17)	K001.3035.0004 	3,5 x 30	5
(M18)	K036.3135.0001 		1

M100.117		Abmessung (mm)	2Anzahl (Stück)
Pos	Bild		V3/4
(M19)	K037.0840.0001 		4
(M20)	K050.1090.0000 		2
(M21)	K045.1460.0001 		1
(M22)	K040.7210.0000 	75/150	1
(M23)	K036.3030.0001 		1
(M24)	K001.9050.0004 	5,0 x 90	2
(M25)	K001.6040.0004 	4,0 x 60	2
(M26)	K001.5035.0001 	3,5 x 50	2
(M27)	K001.4040.0006 	4,0 x 40	12
(M28)	K001.3030.0004 	3,0 x 30	8
(M29)	K001.3040.0006 	4,0 x 30	16
(M30)	K001.2540.0004 	4,0 x 25	4

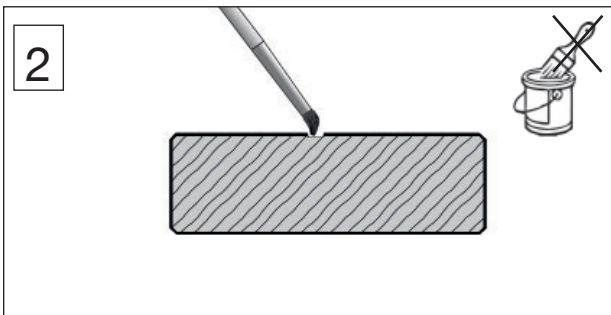
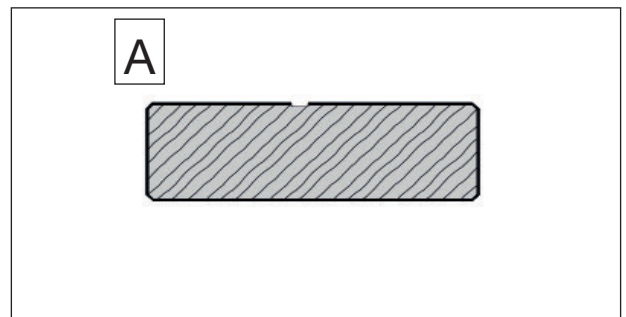
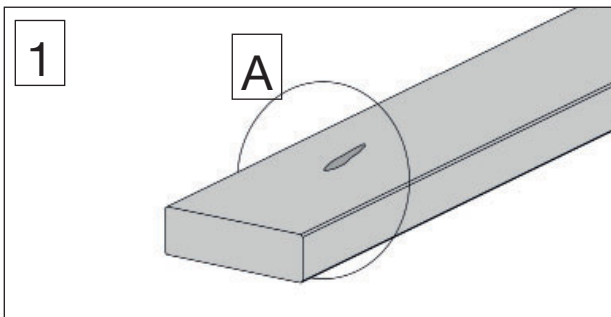
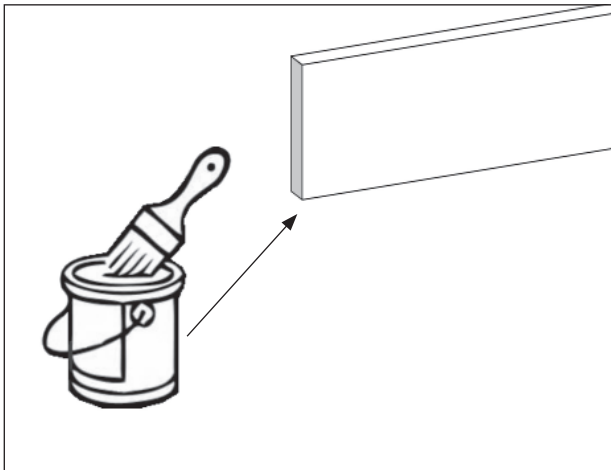
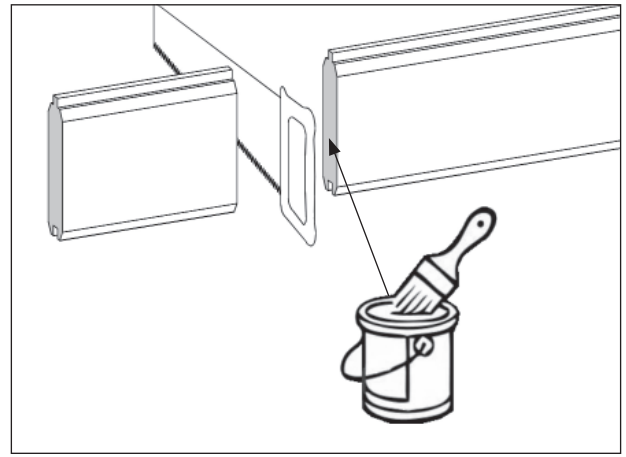
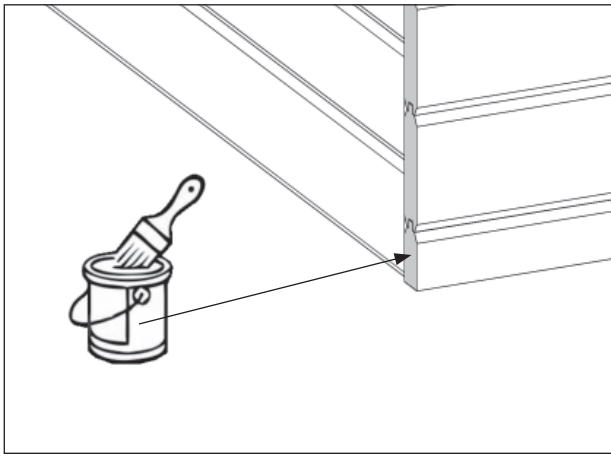

Farbe dünn auftragen und nur auf der Schadstelle.

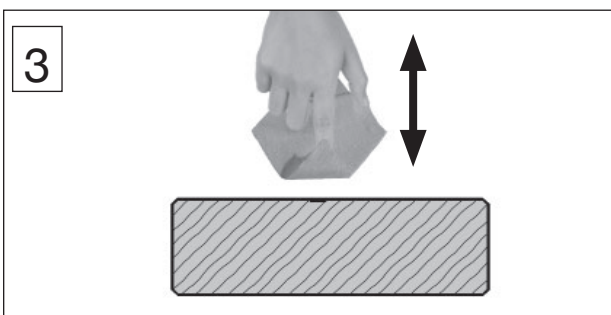
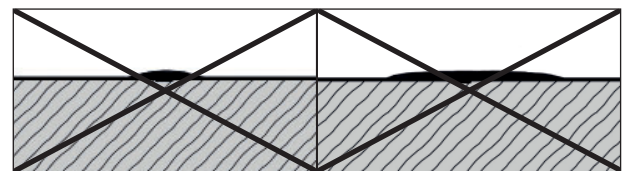

Farbe tupfen
Vorgang wiederholen

V1

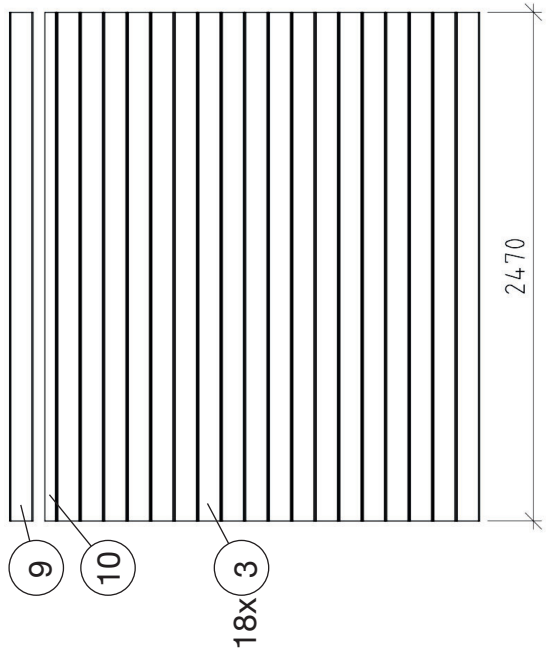
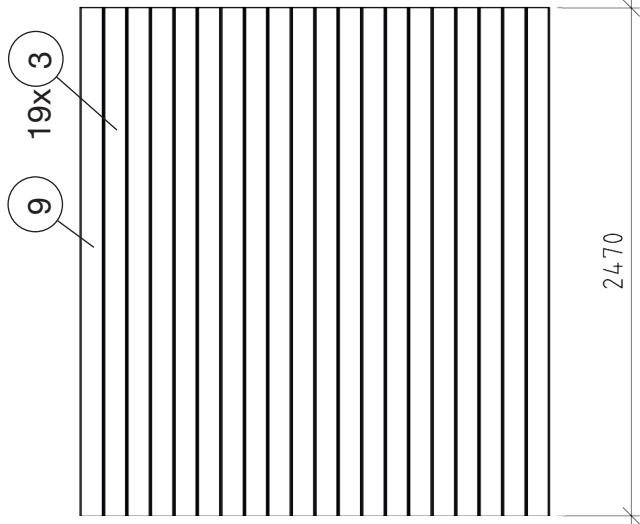
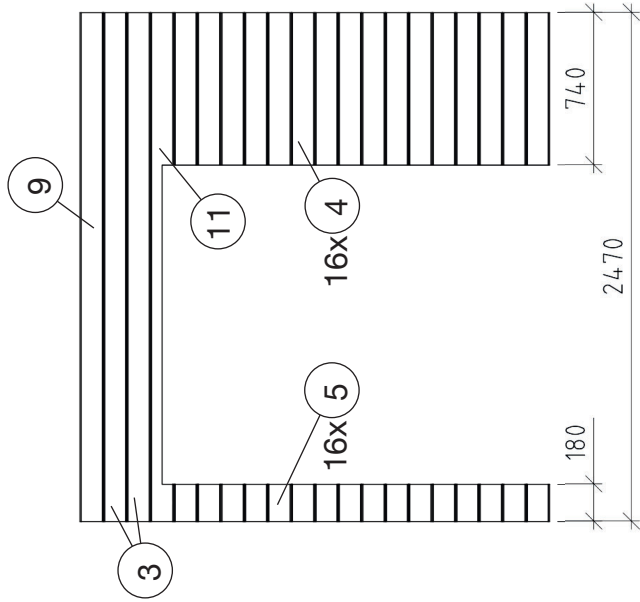
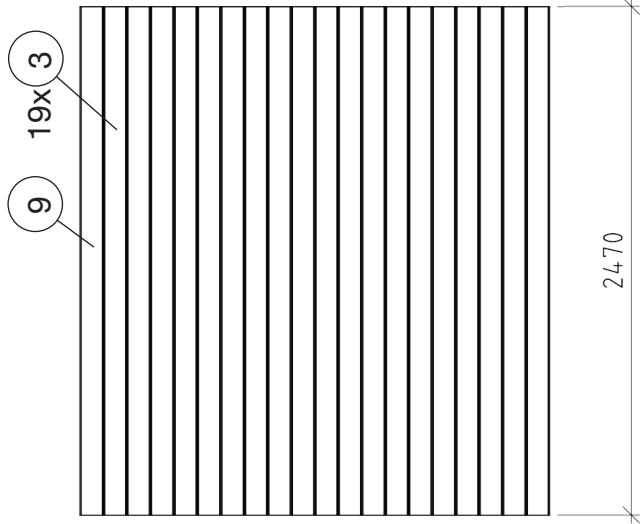

V2 / V3

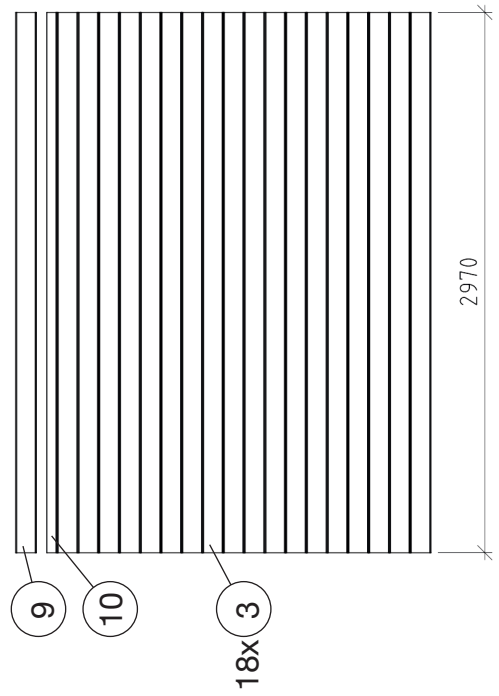
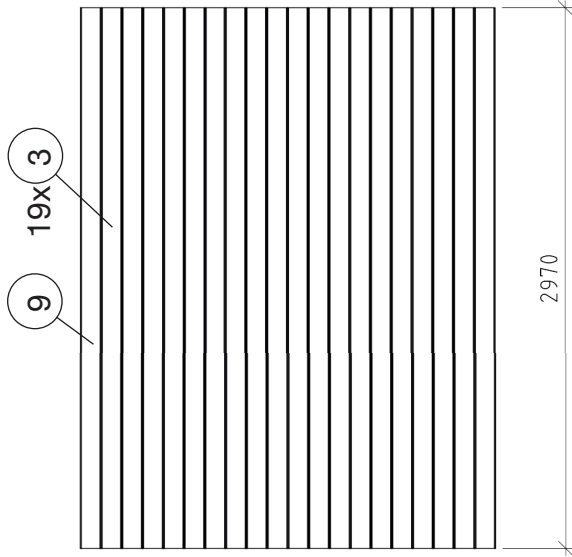
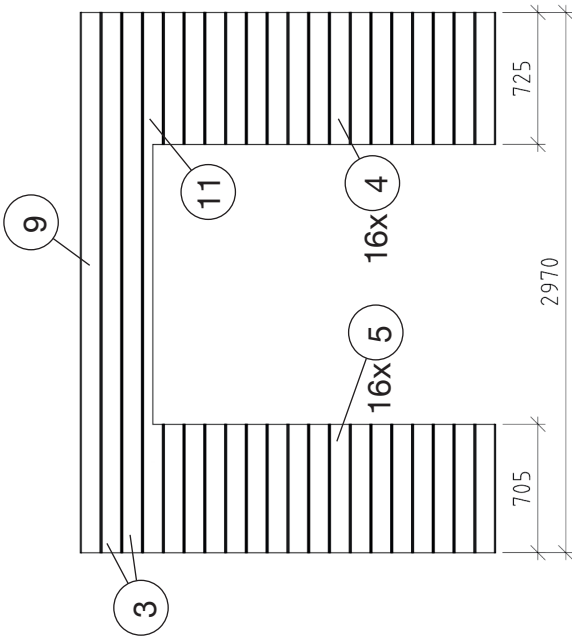
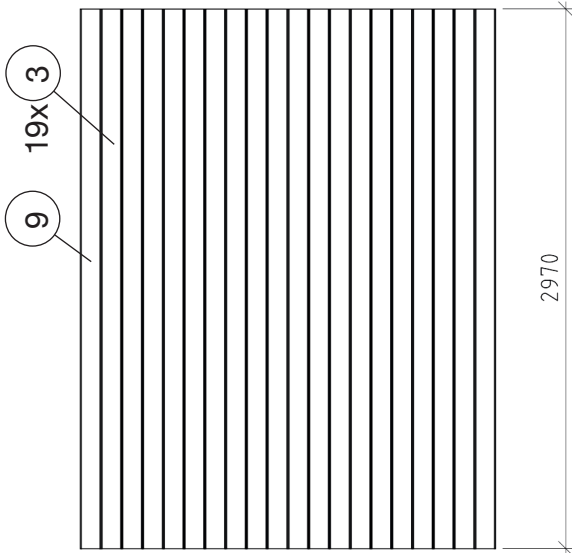

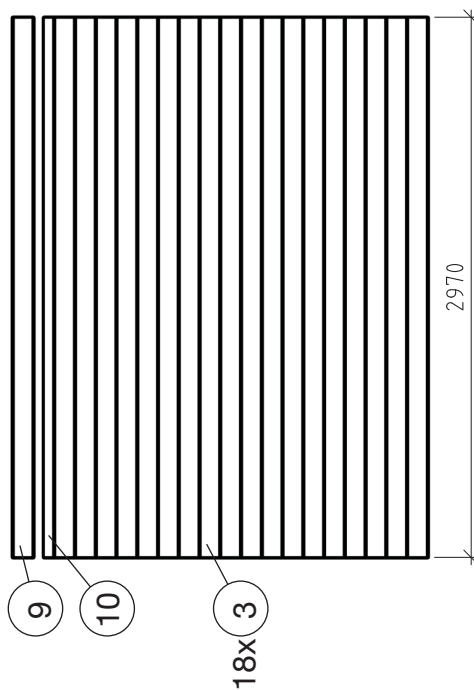
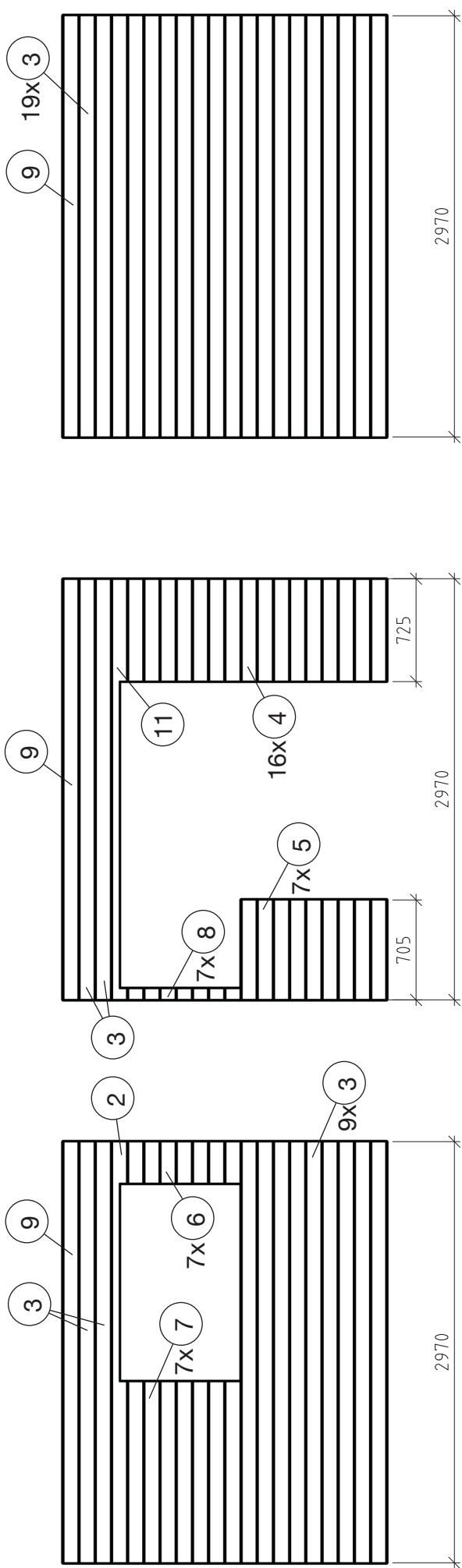

1

Art.-Nr.: 41725254XXXX

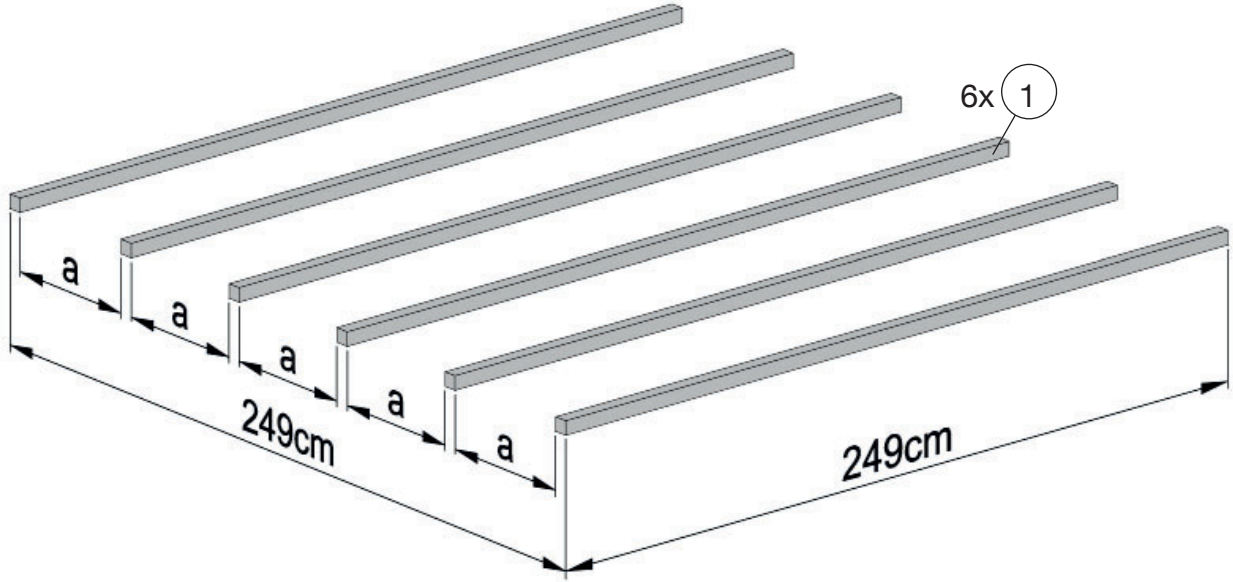

Art.-Nr.: 41730304XXXX

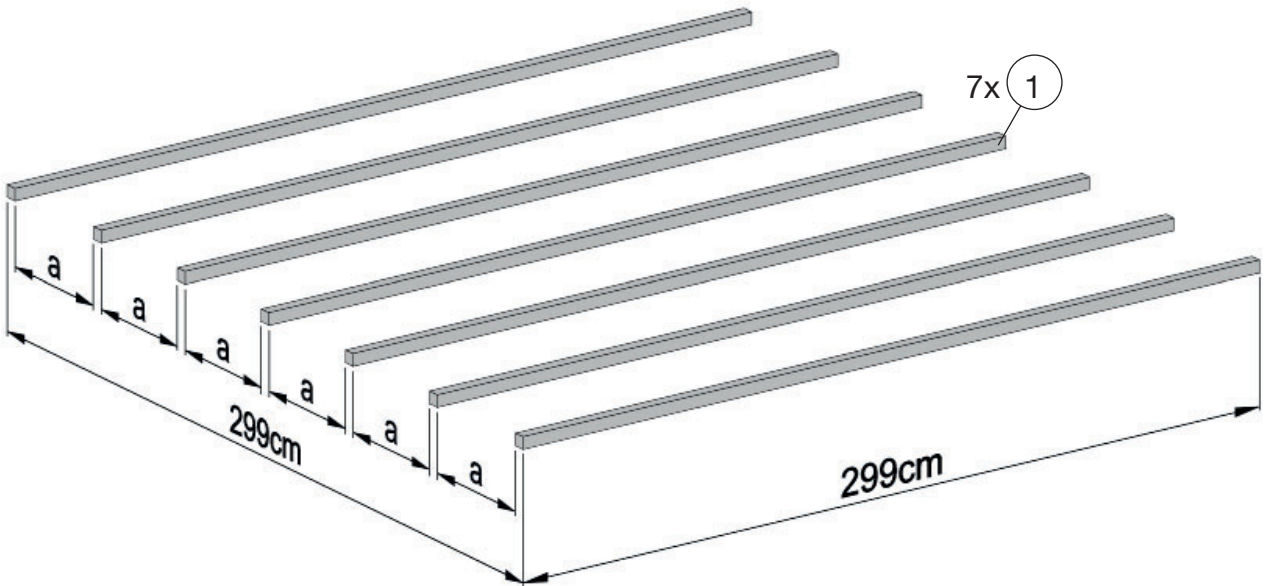

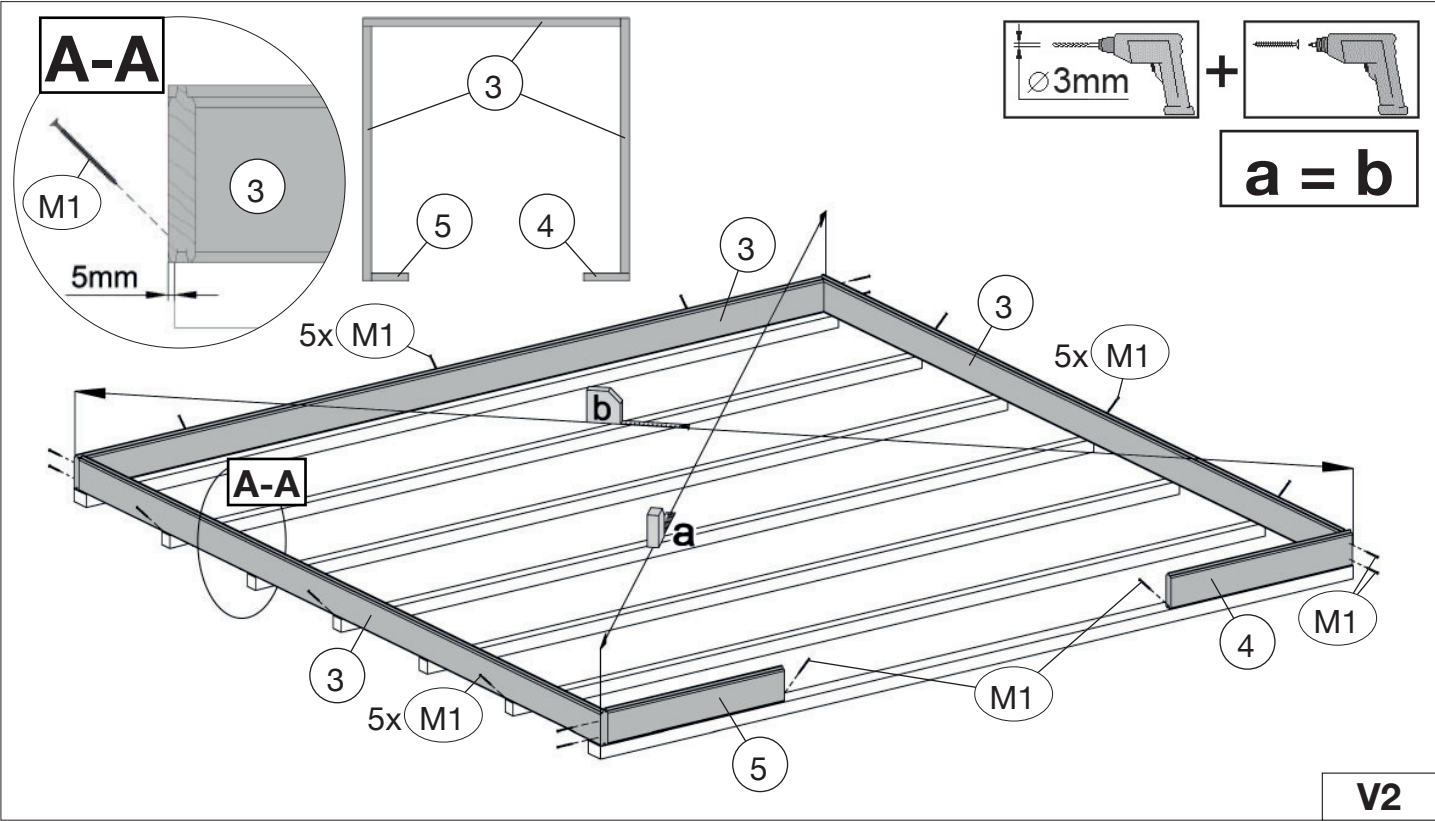

2

	M1 4,0 x 60
--	--------------------



3

			M3 2,2 x 55
---	--	---	--------------------

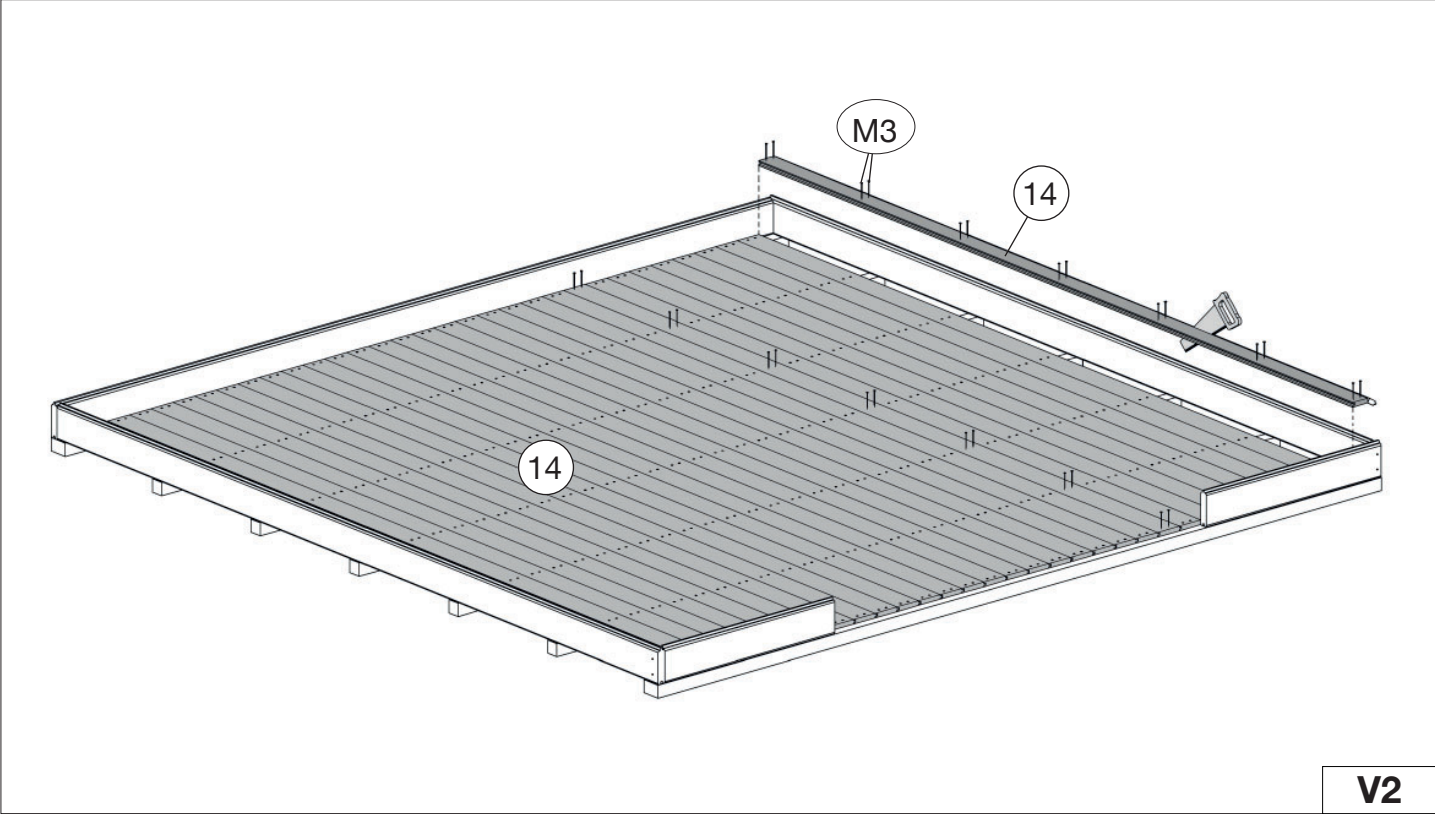

4

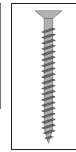
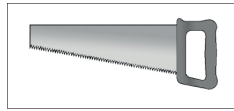
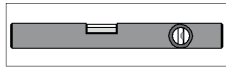

M1 4,0 x 60

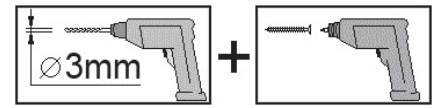
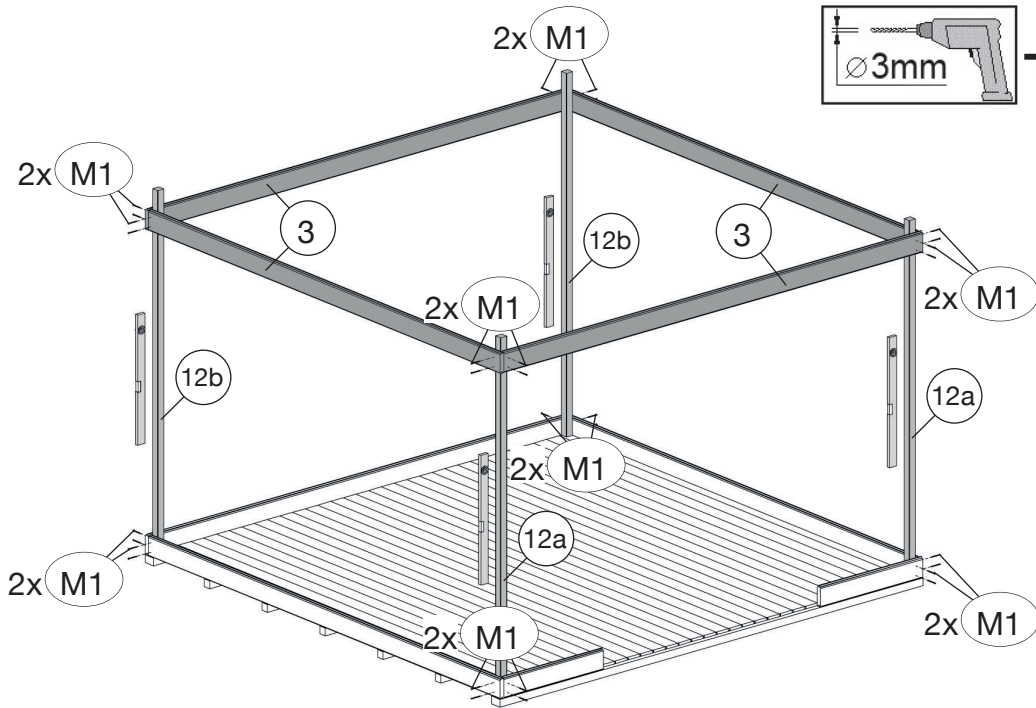

Die oberen Wandbohlen werden nur vorübergehend als Montagehilfe befestigt (Abb.4), später wieder abgenommen und an anderer Stelle montiert. (Abb.8)

V2

5

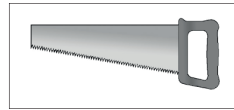
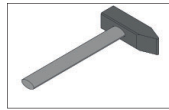

M3 2,2 x 55

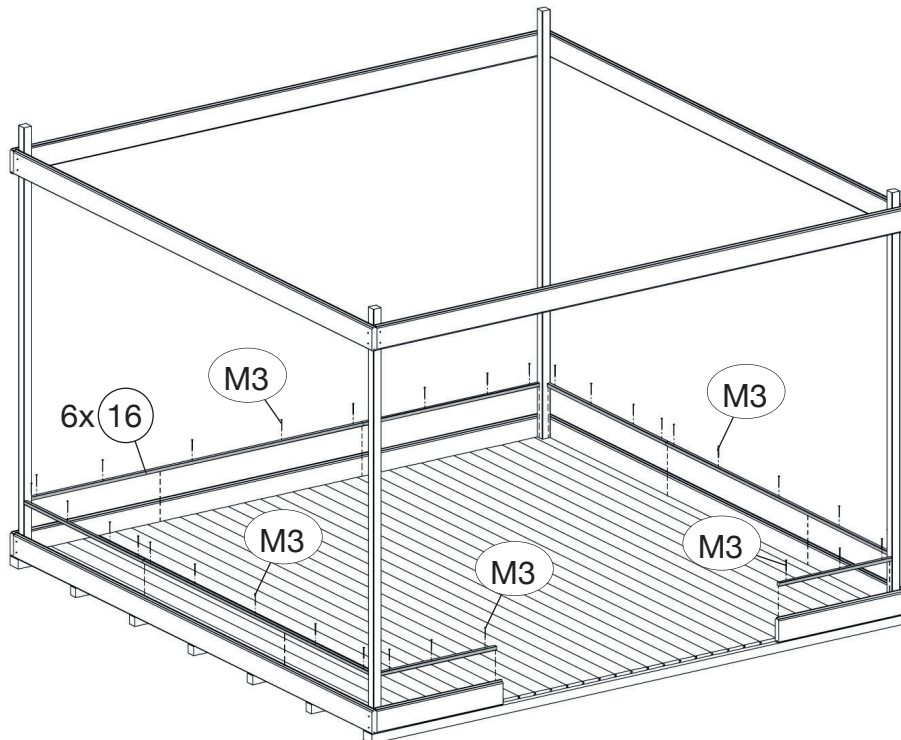

V2

6

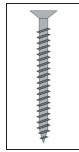
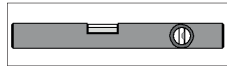

M1 4,0 x 60

a = b

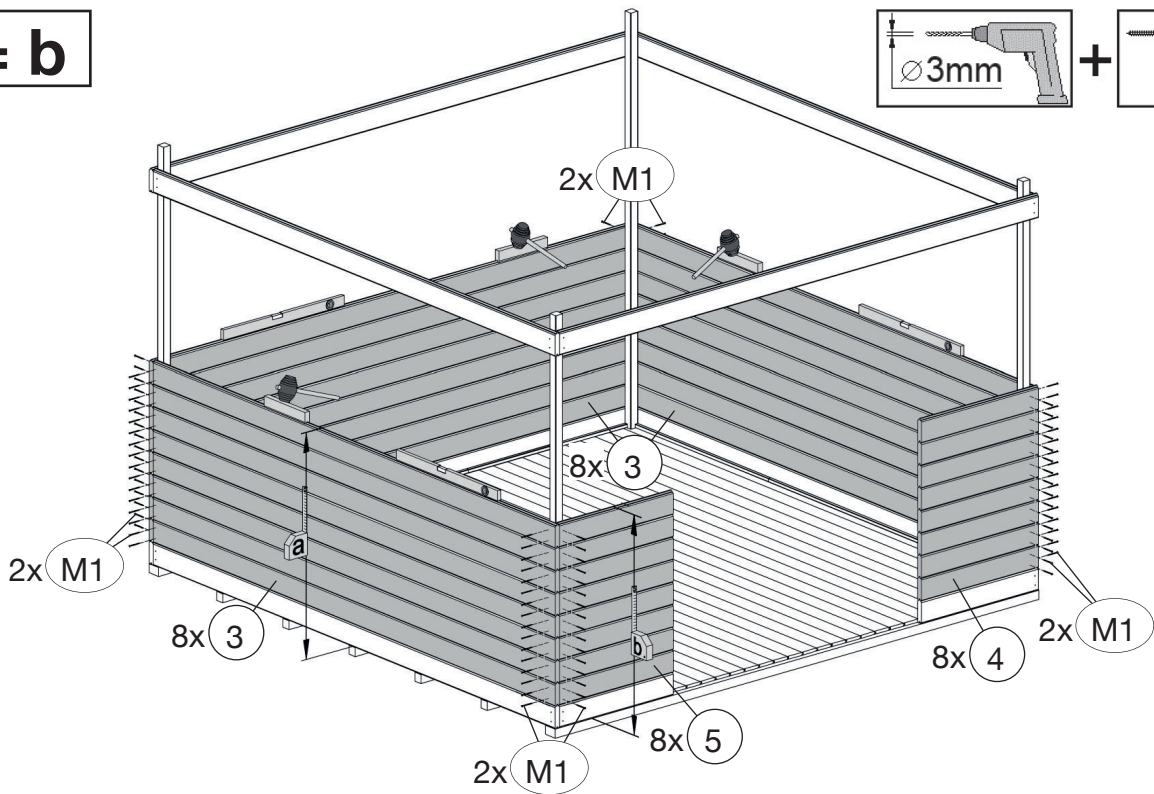
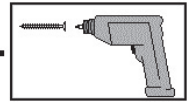
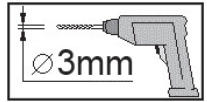

V2

7

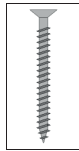
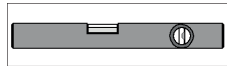

M1 4,0 x 60

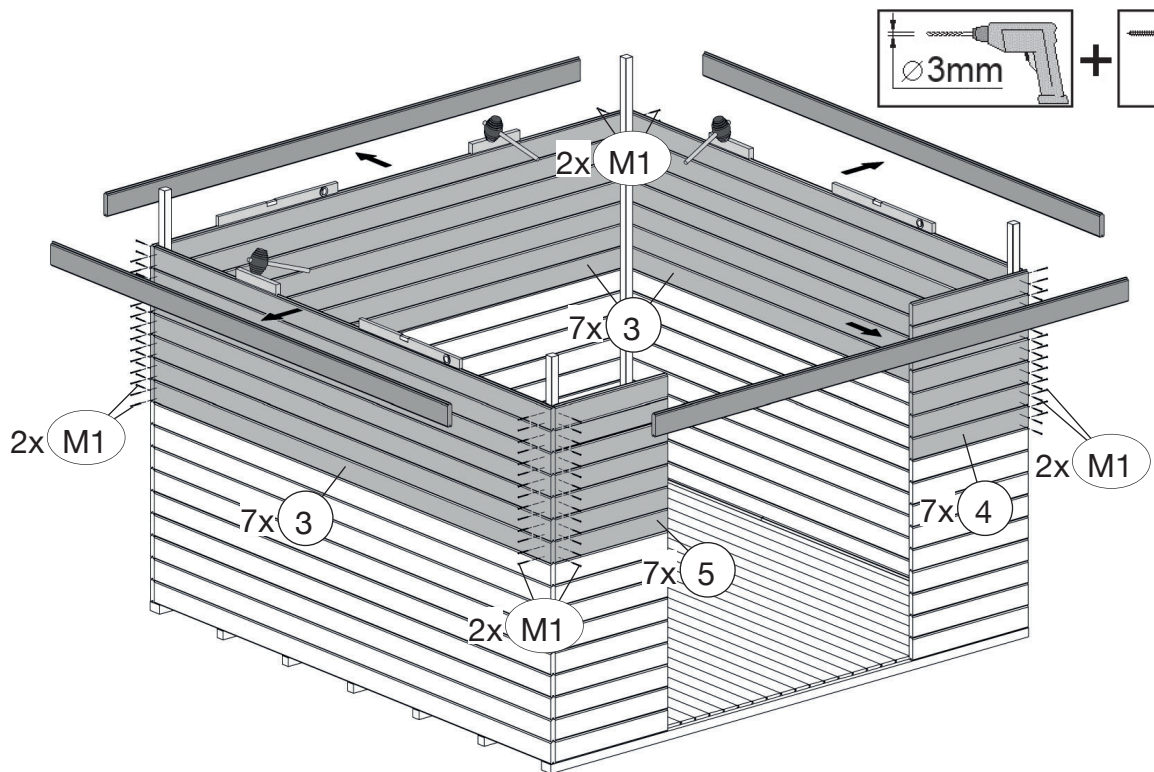
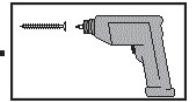
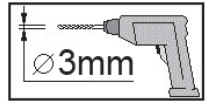

V2

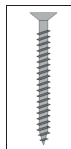
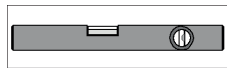

M1 4,0 x 60

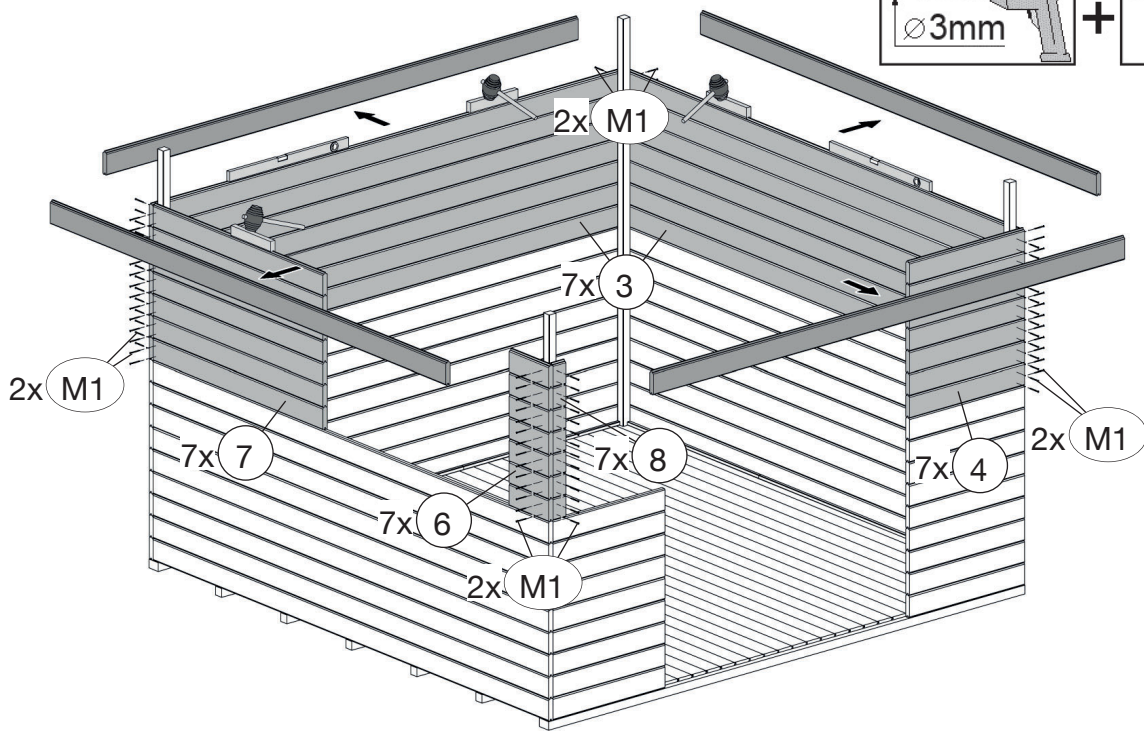
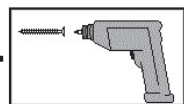
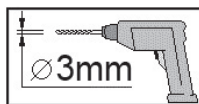

V4

8

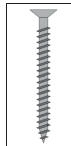
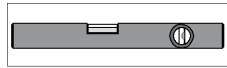

M1 4,0 x 60

M4 3,5 x 30

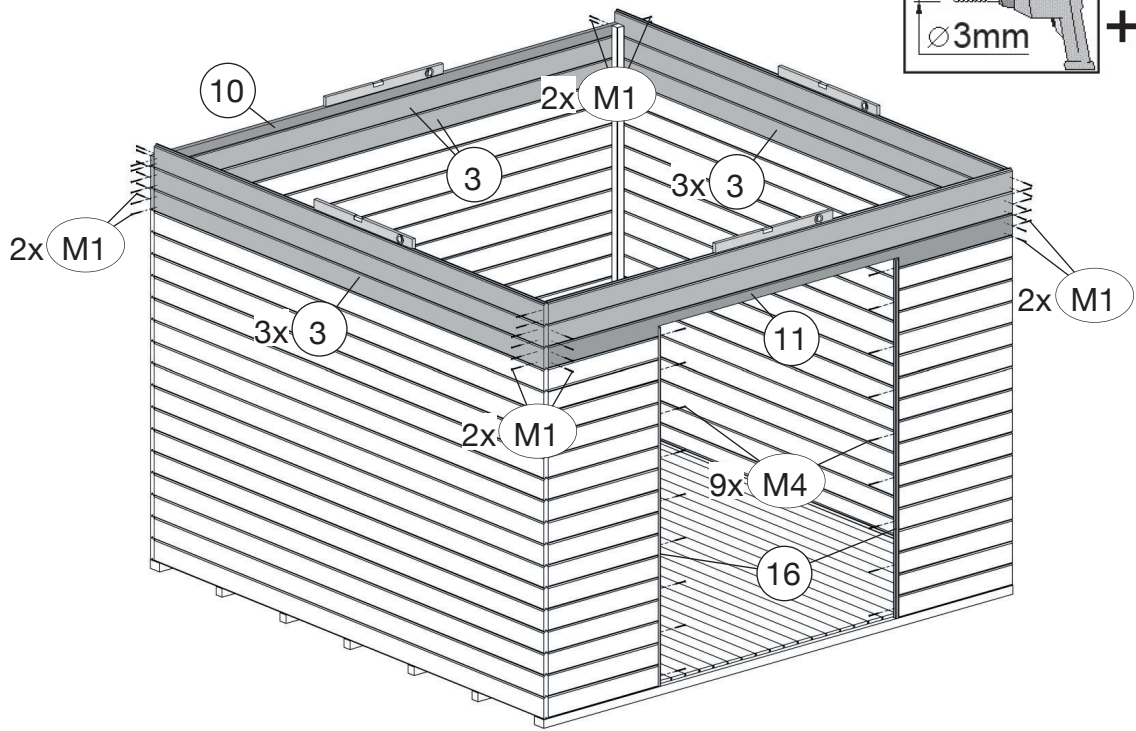
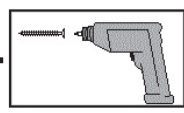
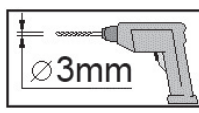

V2

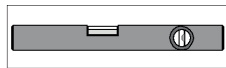

	M1	4,0 x 60
	M2	4,0 x 40

	M4	3,5 x 30

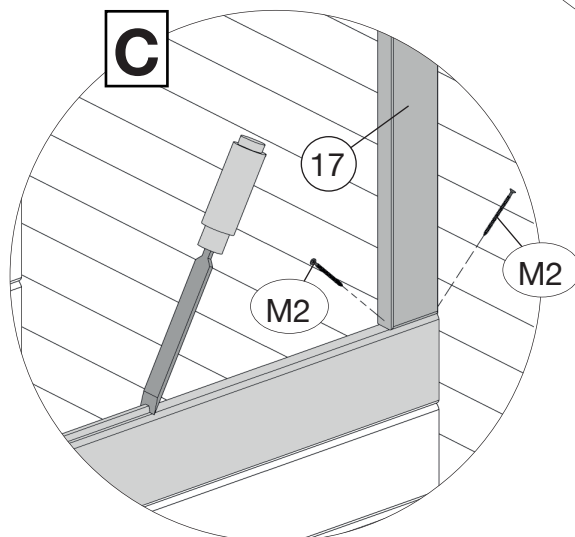
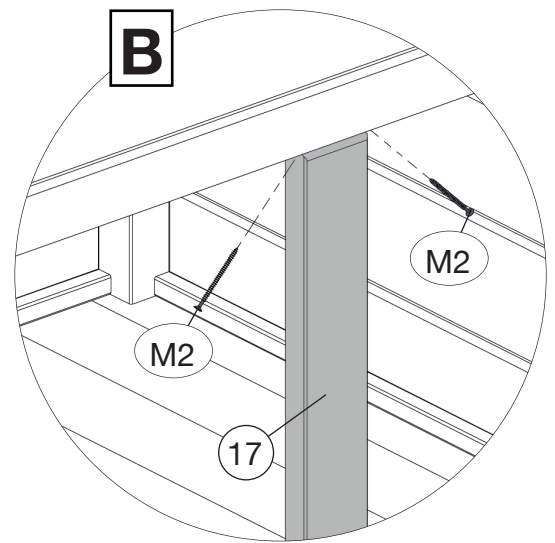
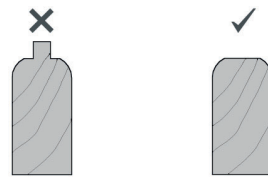
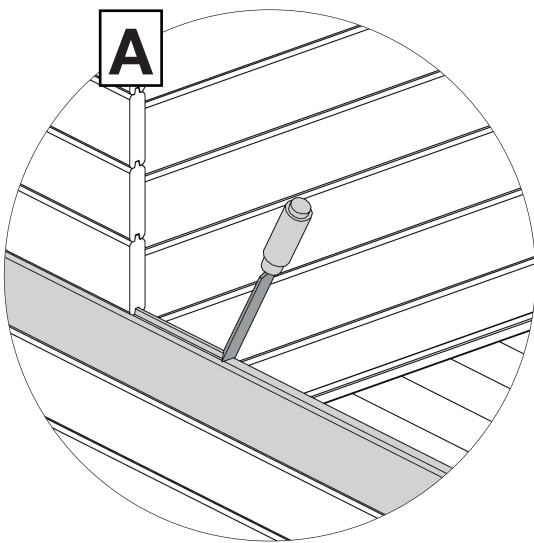
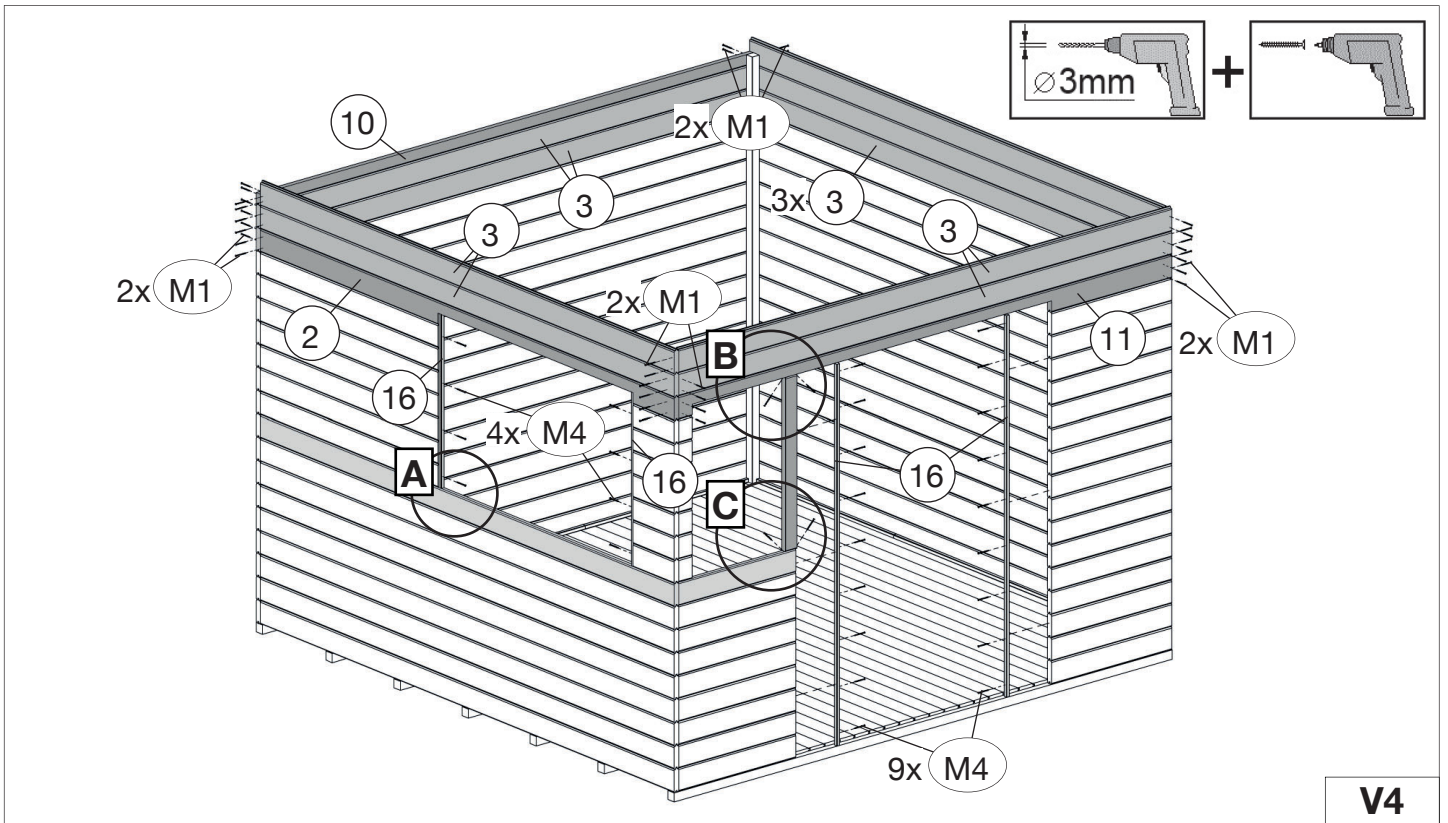
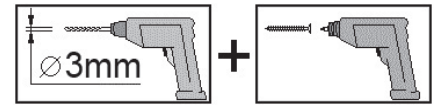

9

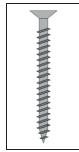
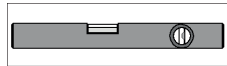

M1 4,0 x 60

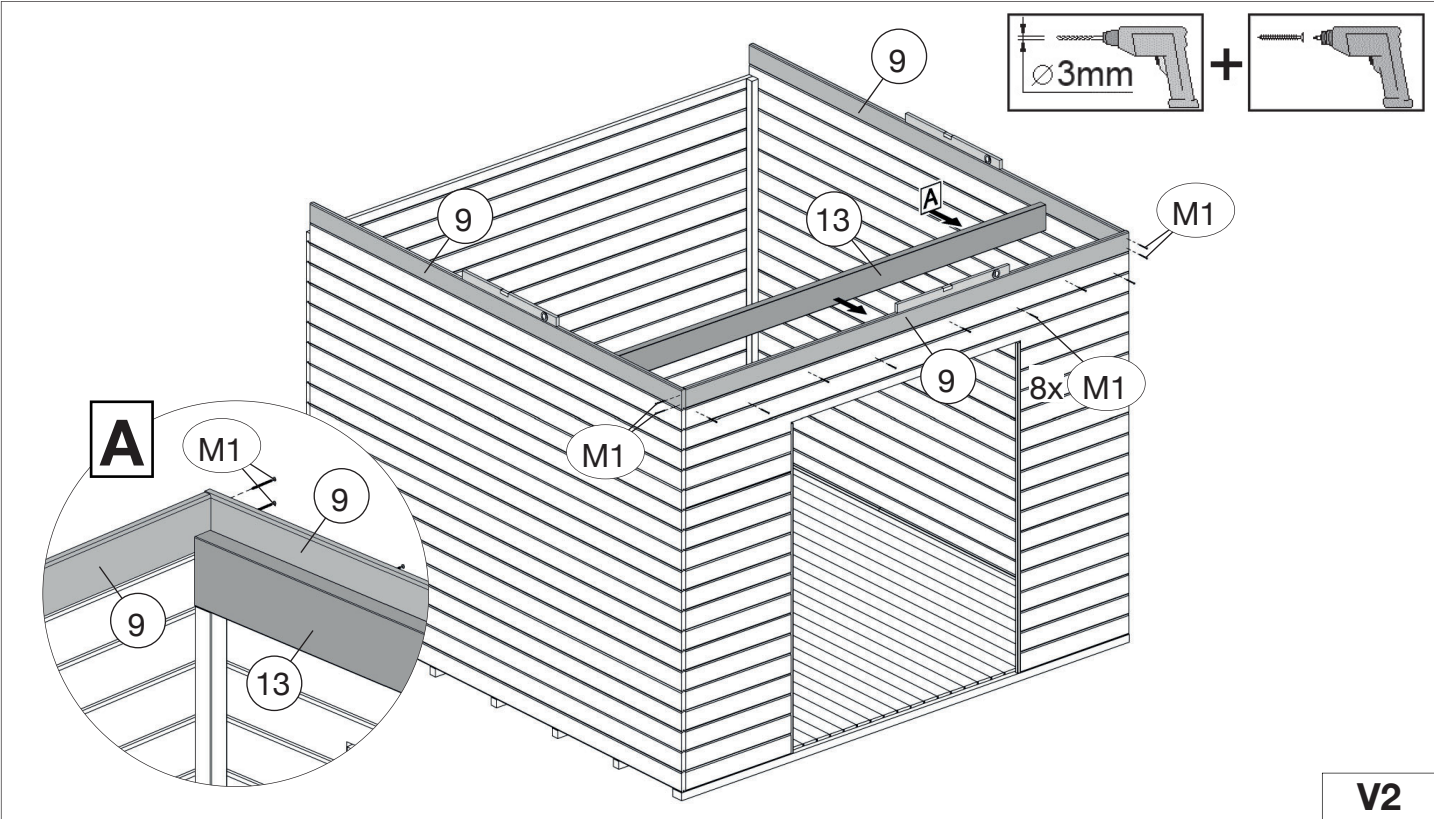
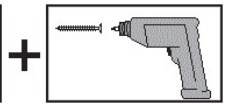
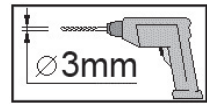

10

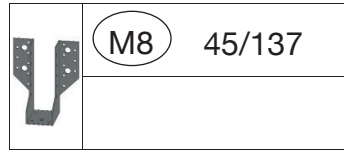

M8 45/137

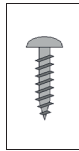

M5 3,5 x 16

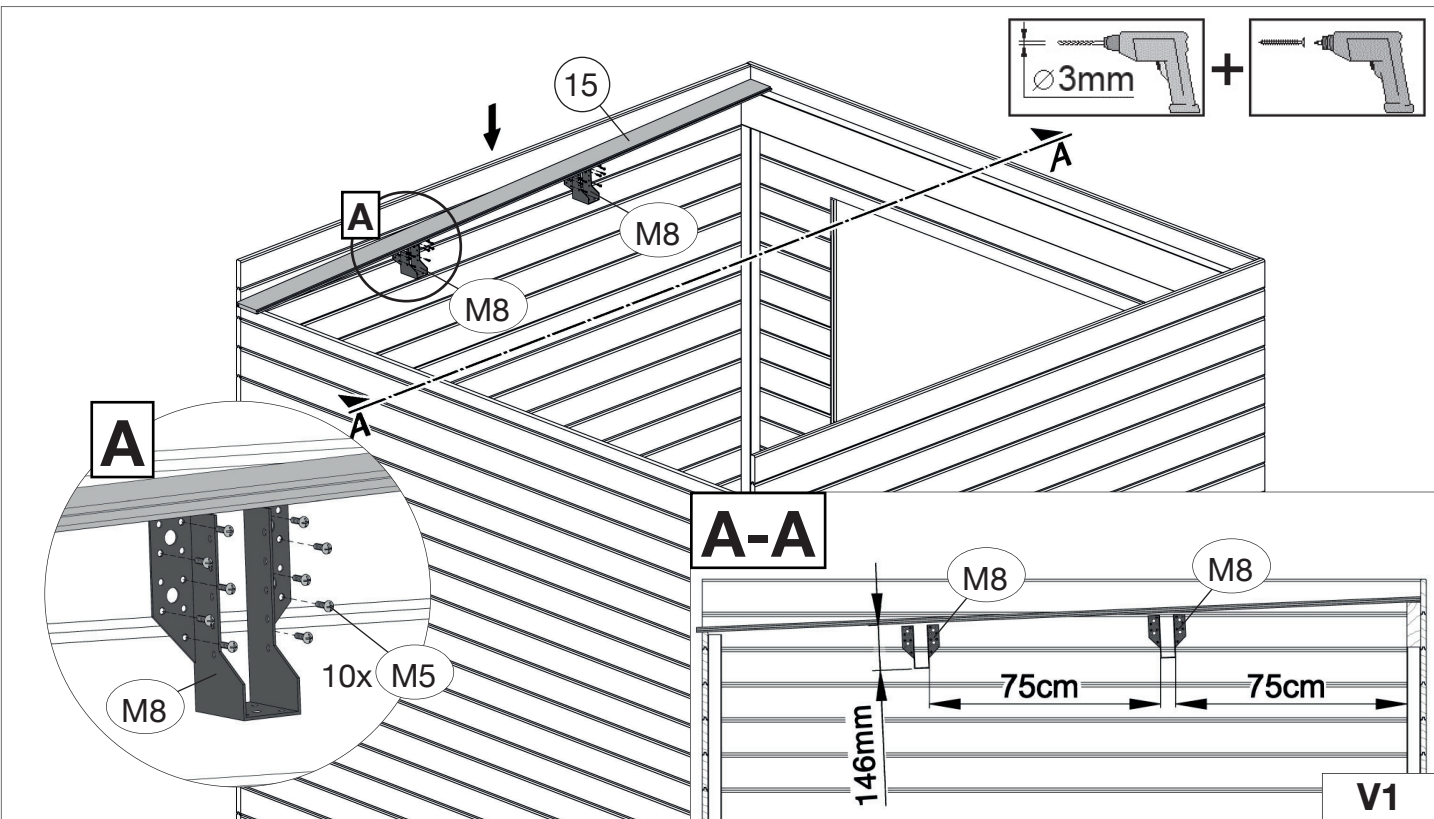
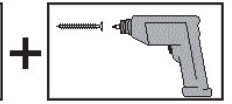
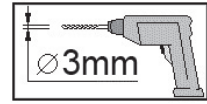

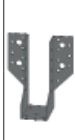
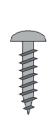
	M8	45/137		M5	3,5 x 16
--	----	--------	--	----	----------

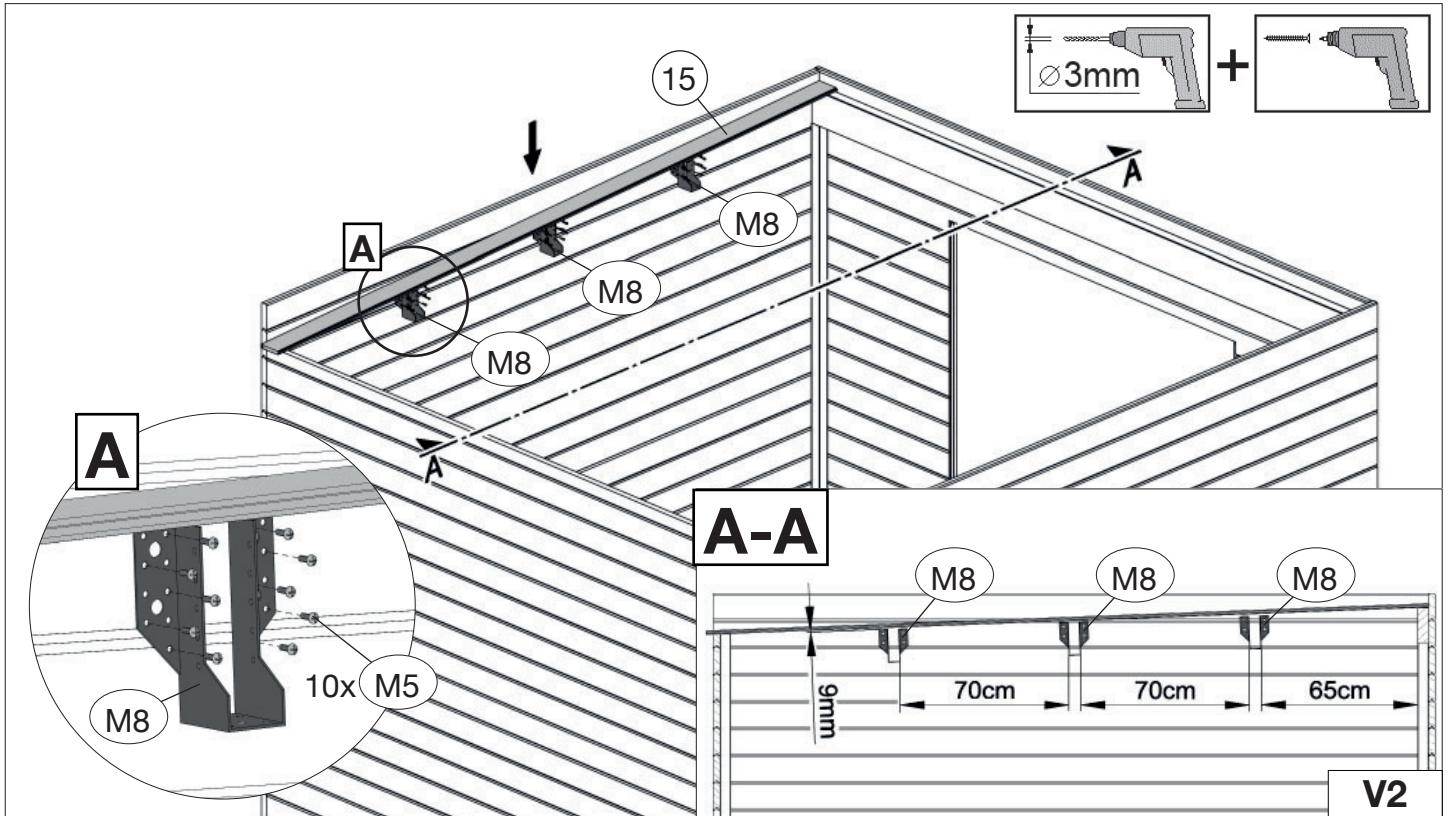

11

	M5	3,5 x 16
---	----	----------

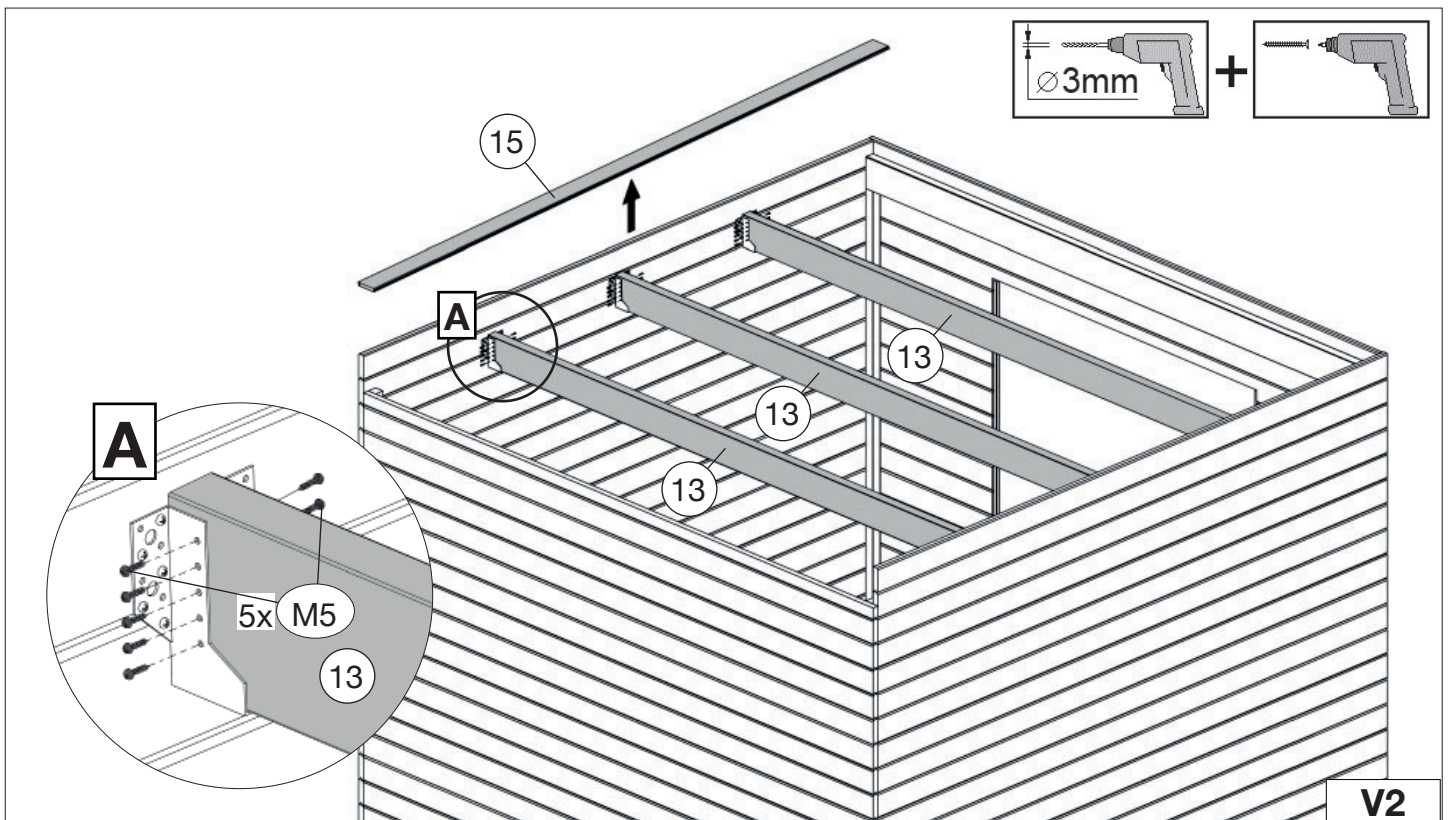

12

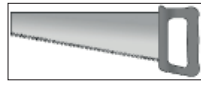

M3	2,2 x 55
----	----------

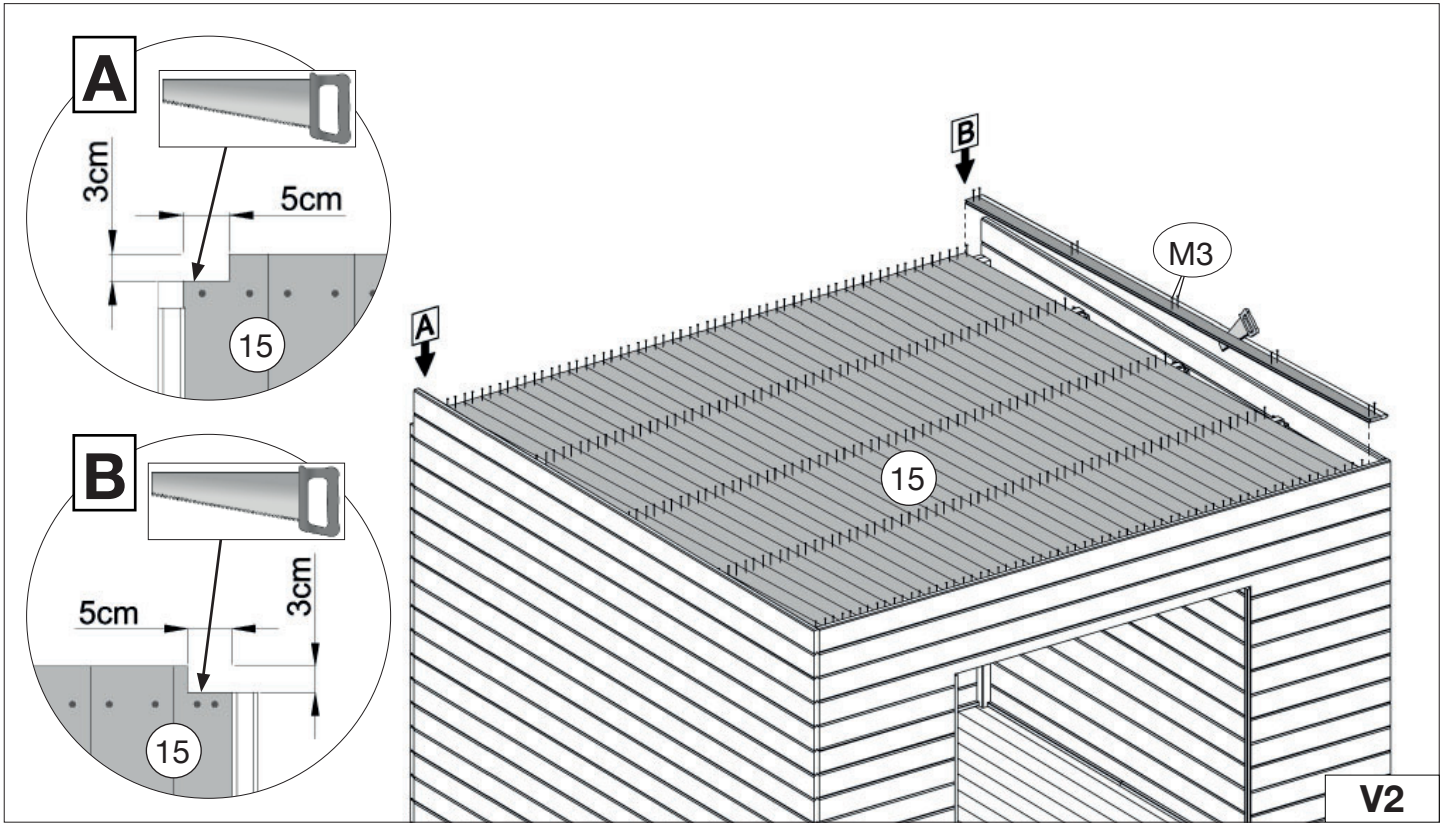

13

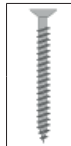
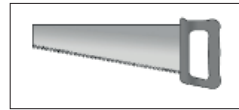

M1	4,0 x 60
M4	3,5 x 30

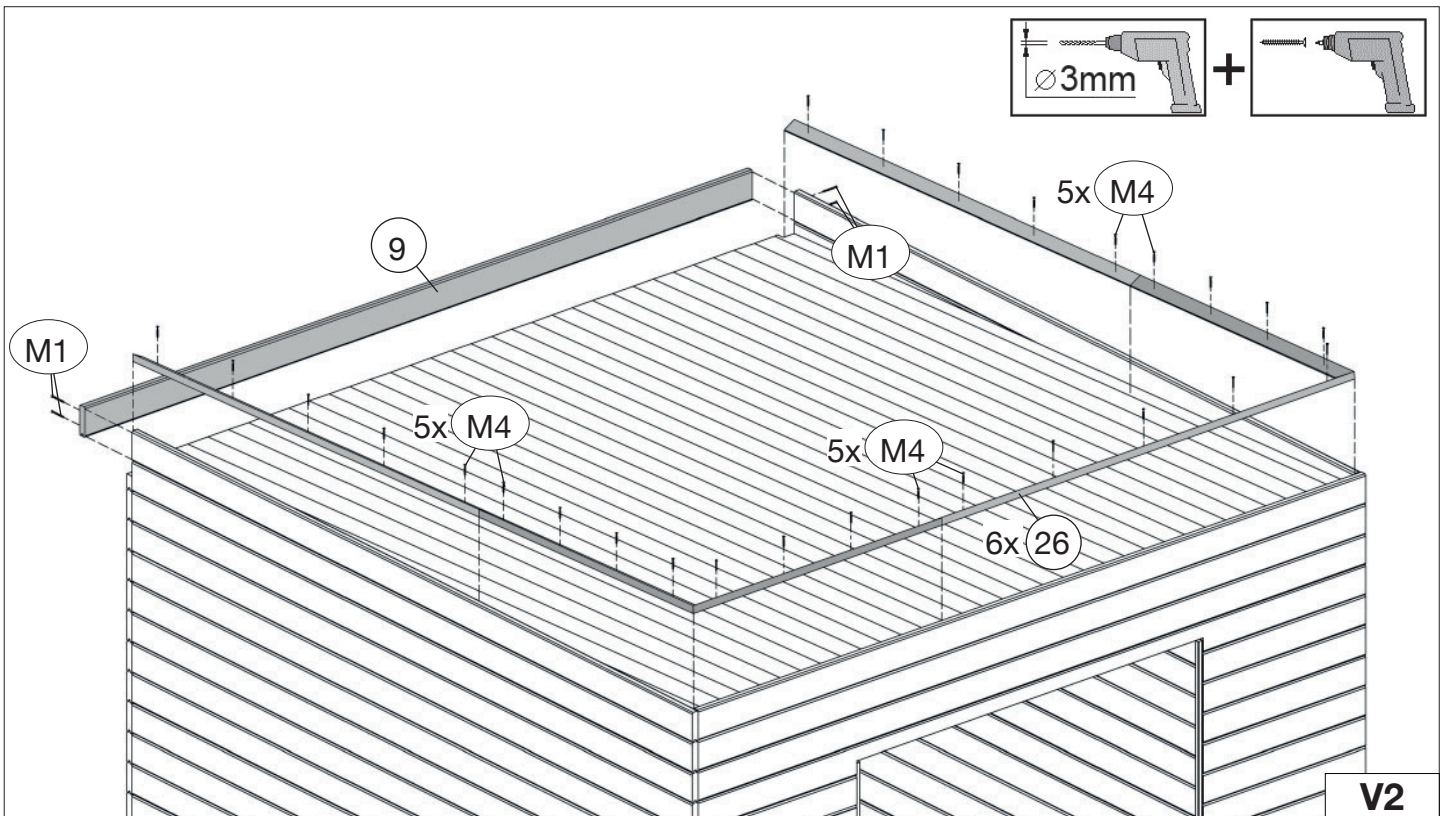

14.1

	M16	3,5 x 16

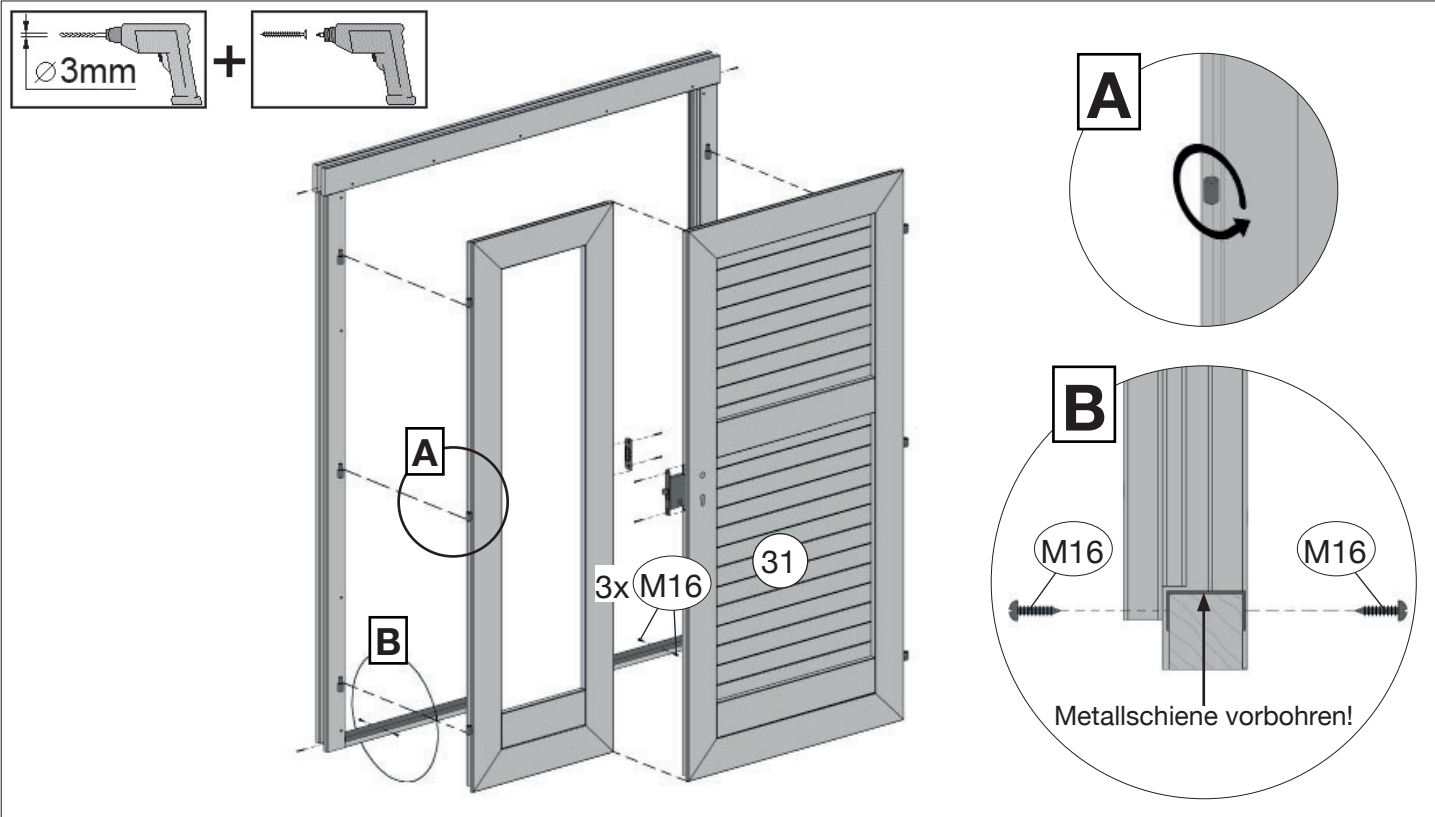

14.2

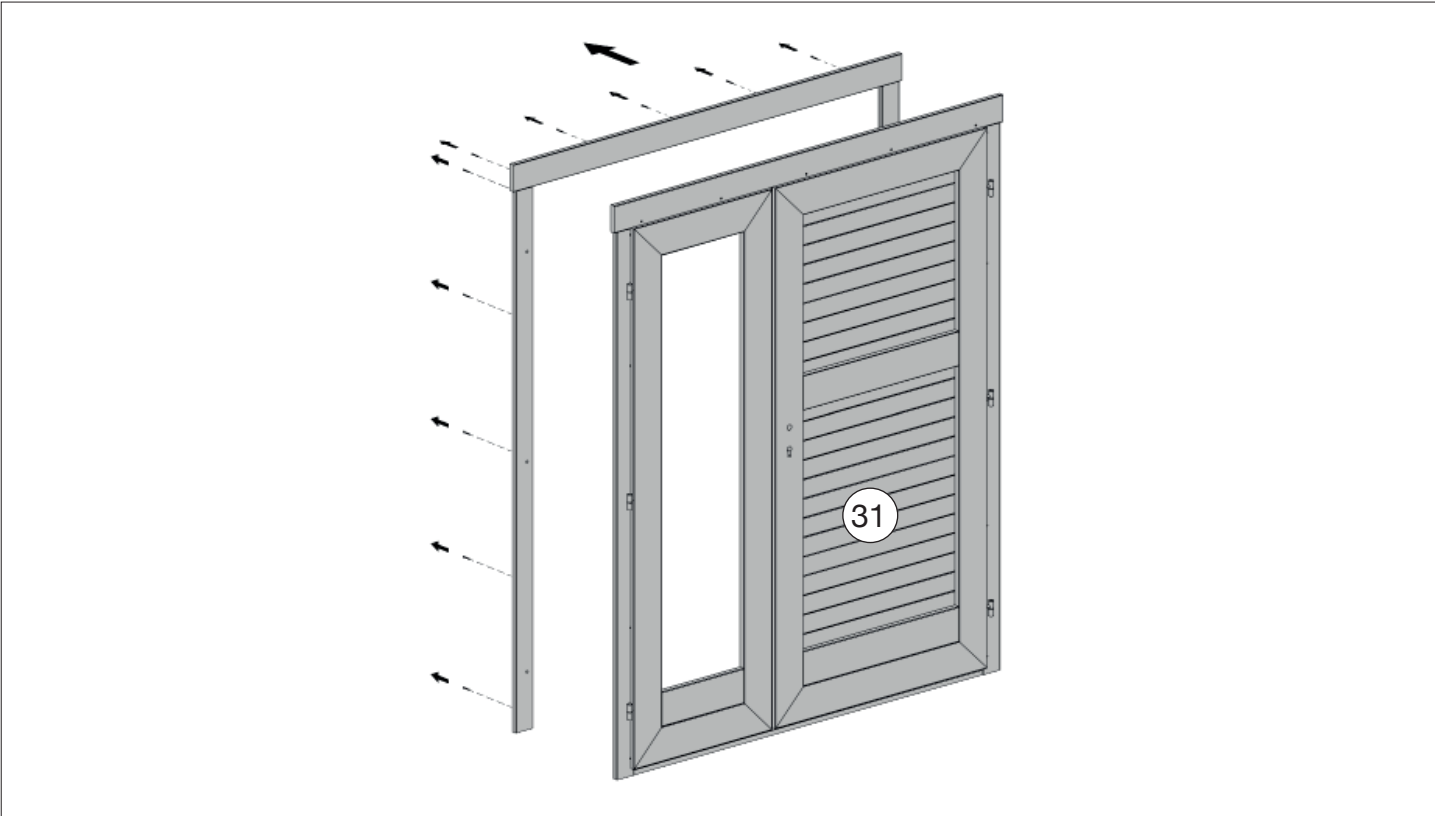

14.3

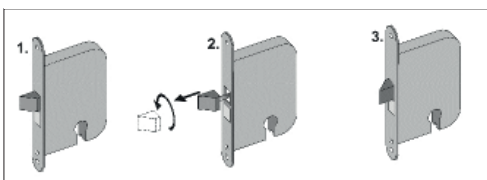
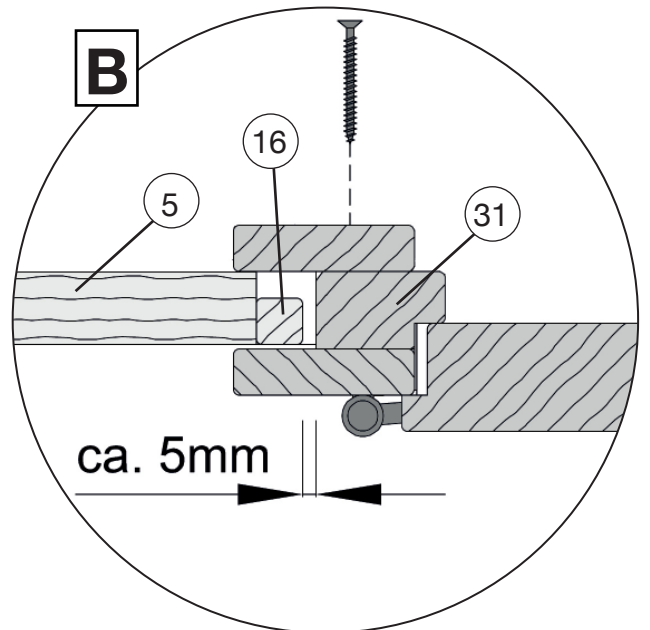
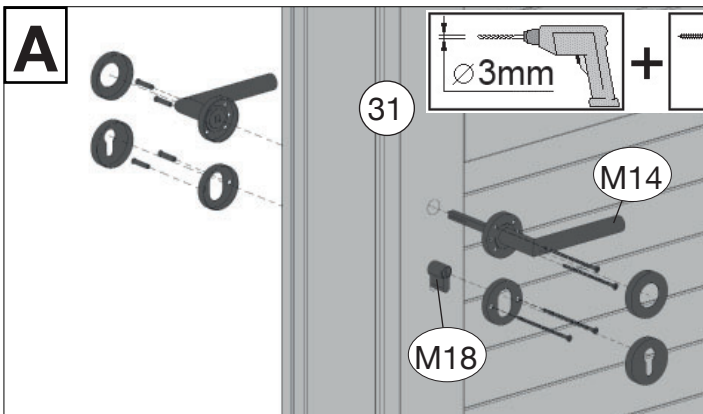
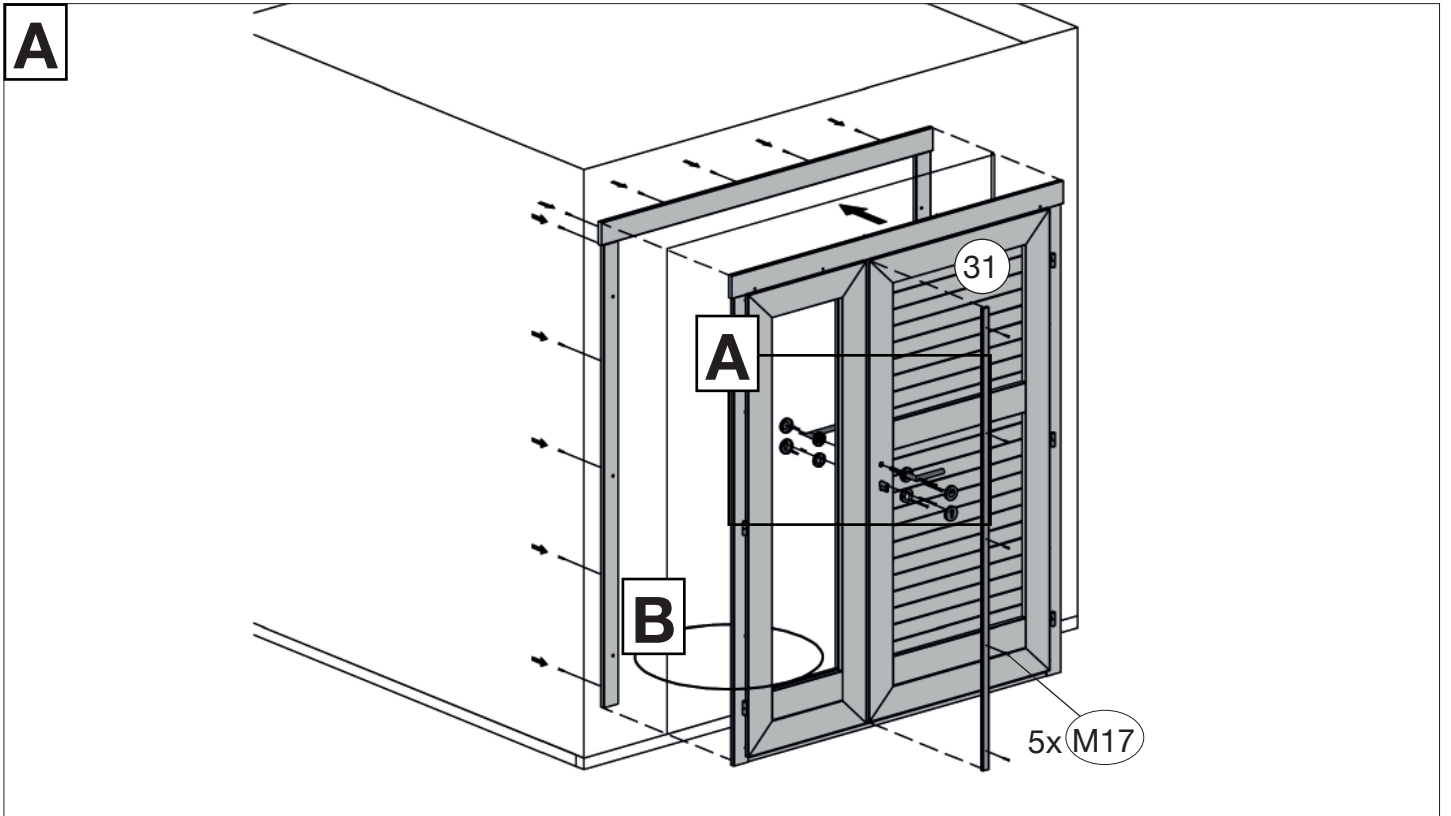
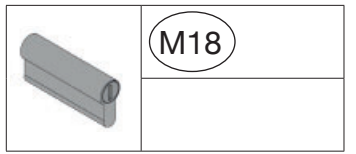
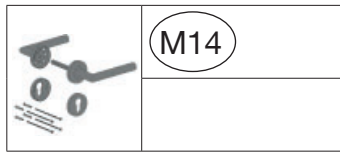

14.1



M19

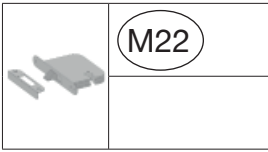

M22



M25 4,0 x 60

M26 3,5 x 50



M27 4,0 x 40

M29 4,0 x 30

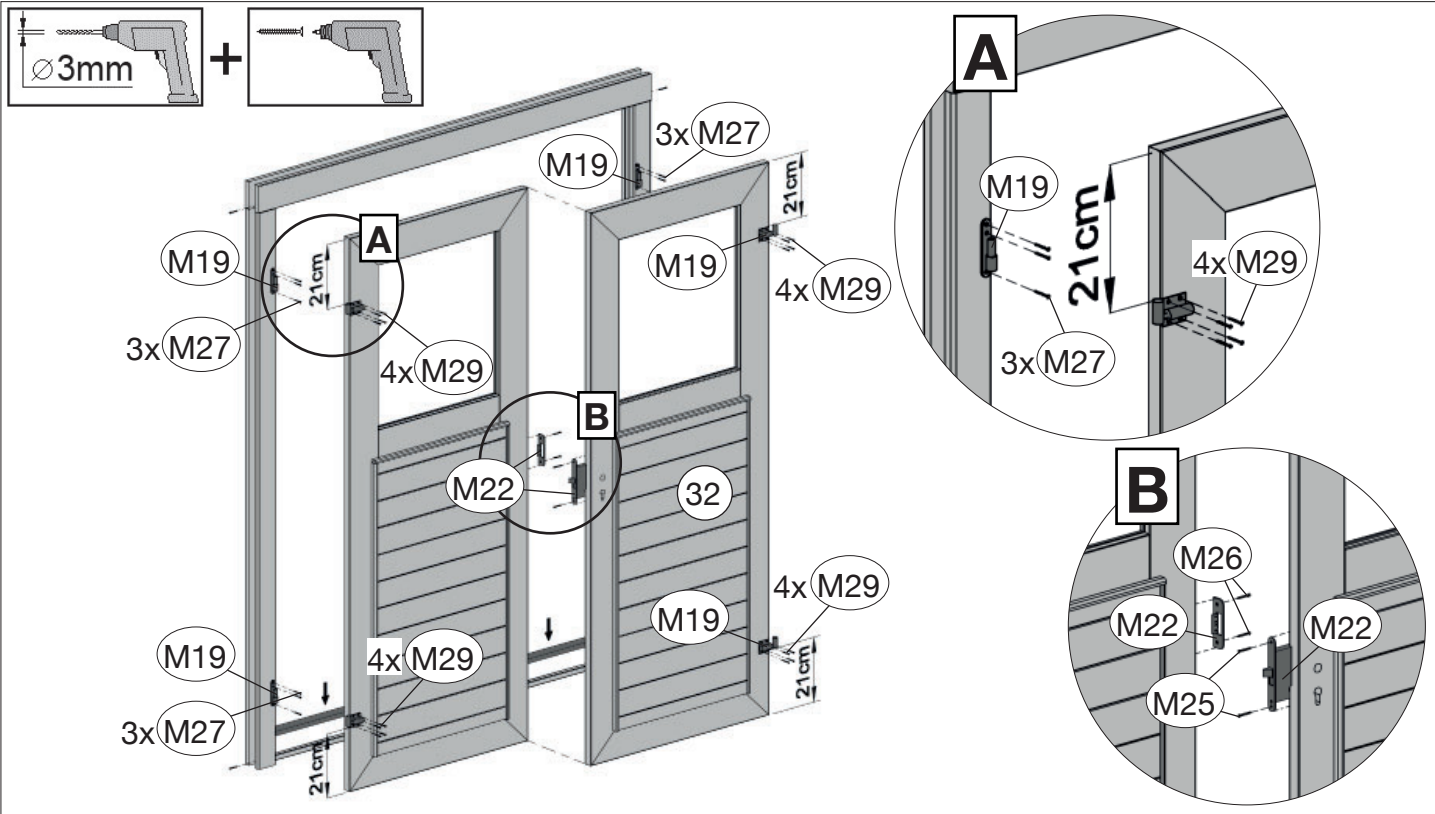
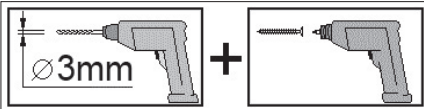

14.2

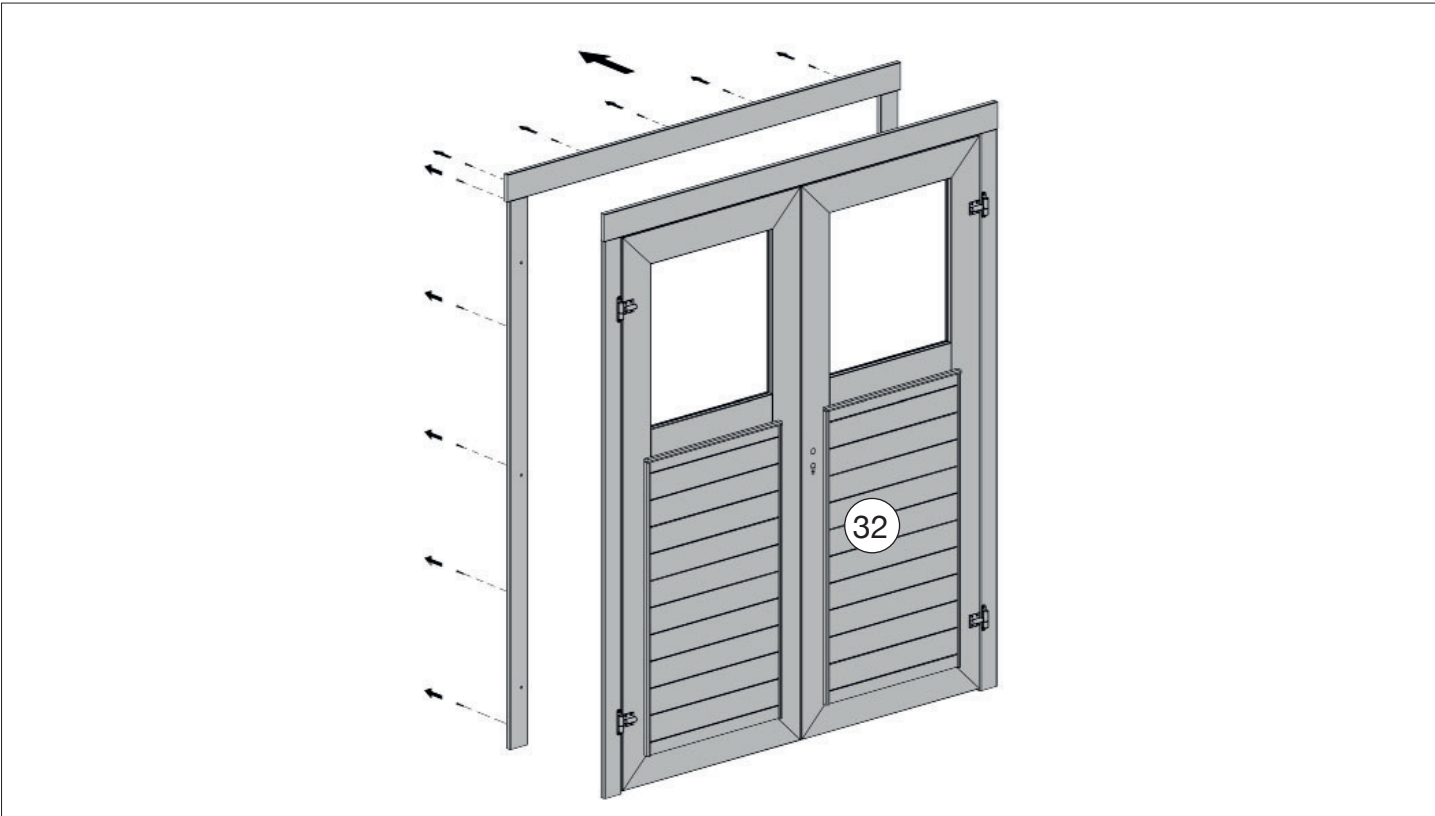

14.3

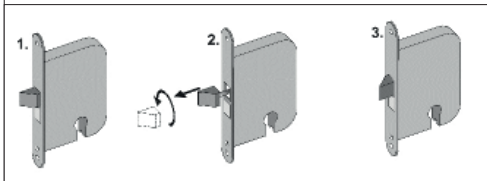
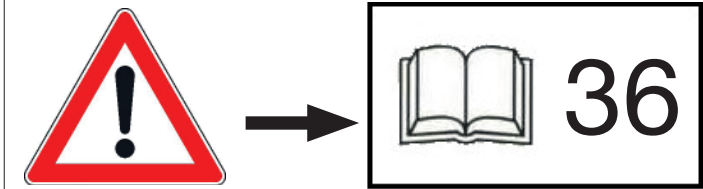
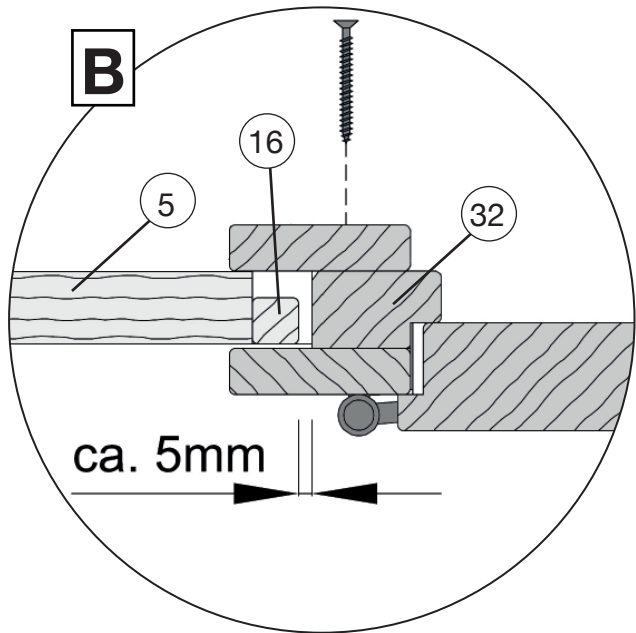
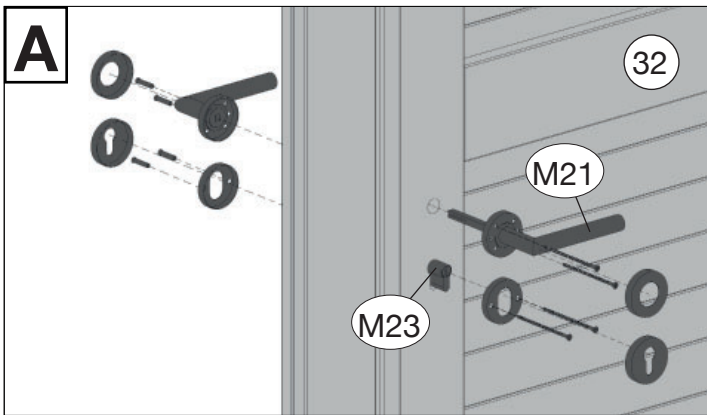
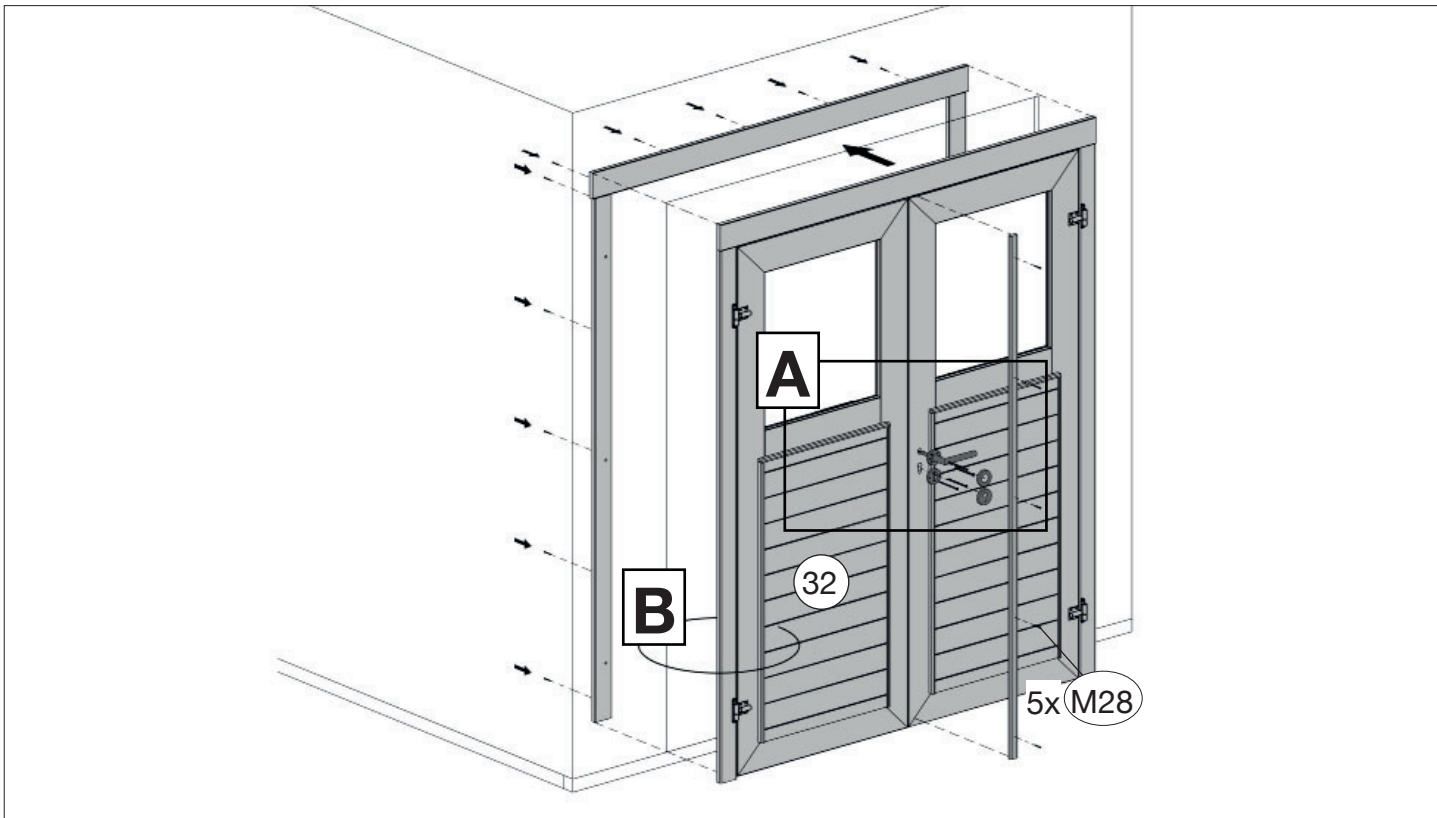
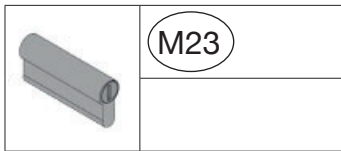
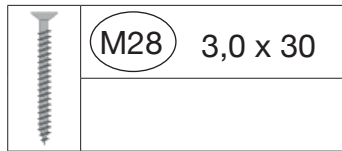
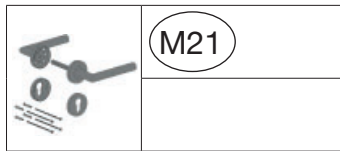

Nachstellen/Justieren der Türflügel

Trotz fachgerechter Montage der Tür lässt es sich nicht umgehen, das Sie, besonders in der Anfangszeit und bei extremer Witterungsfolge die Gängigkeit der Türflügel regelmäßig prüfen und nachstellen.

Durch Herein- und Herausschrauben der Scharnierbänder ist ein Nachjustieren der Türflügel möglich. Holz ist ein Naturprodukt, daher ist leichter Verzug bei Massivholz-Türblättern leider nie ganz auszuschließen.

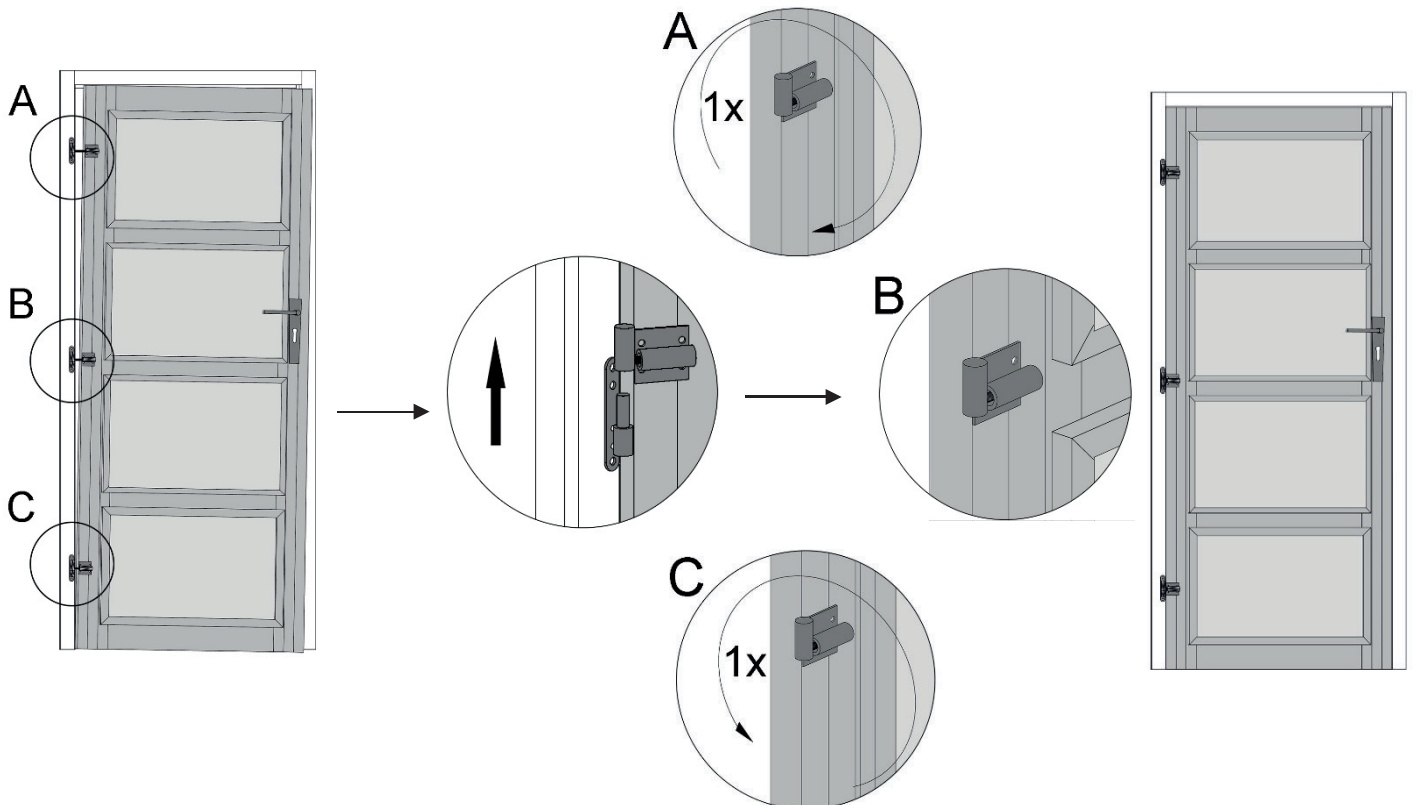
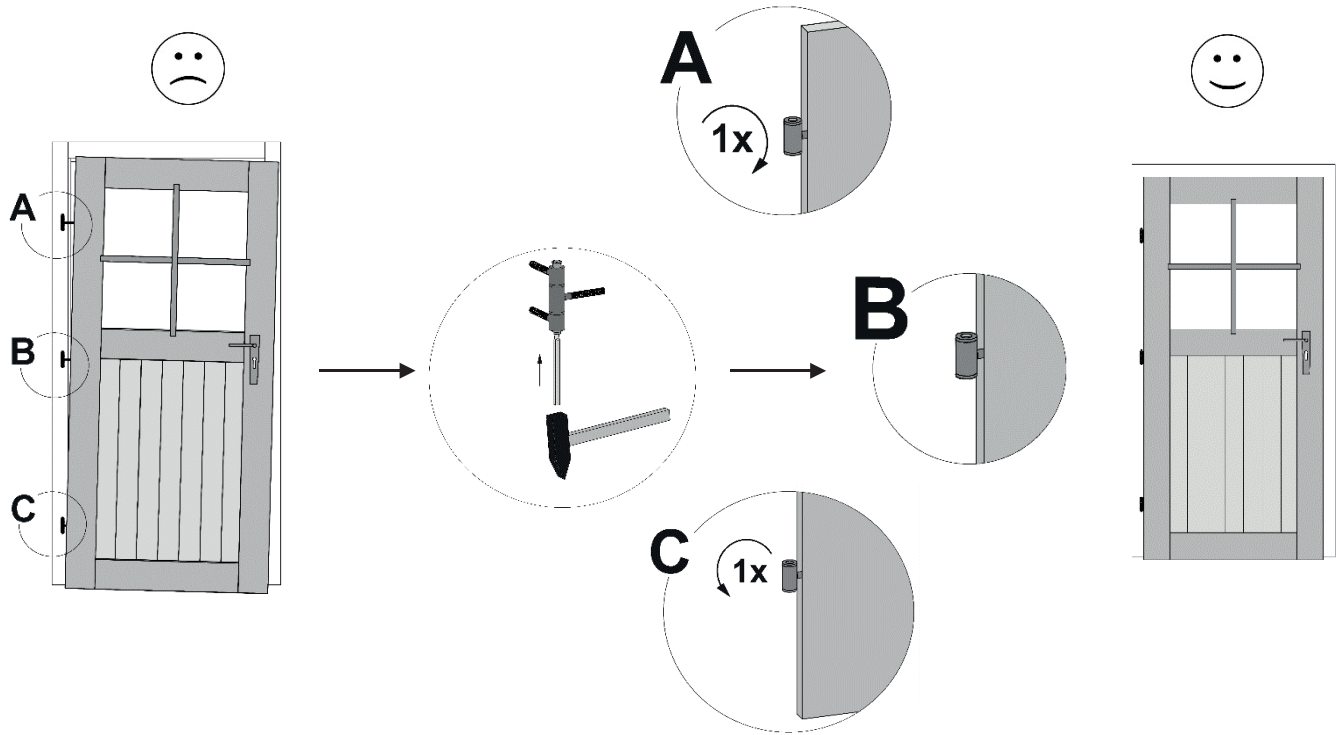

15.1

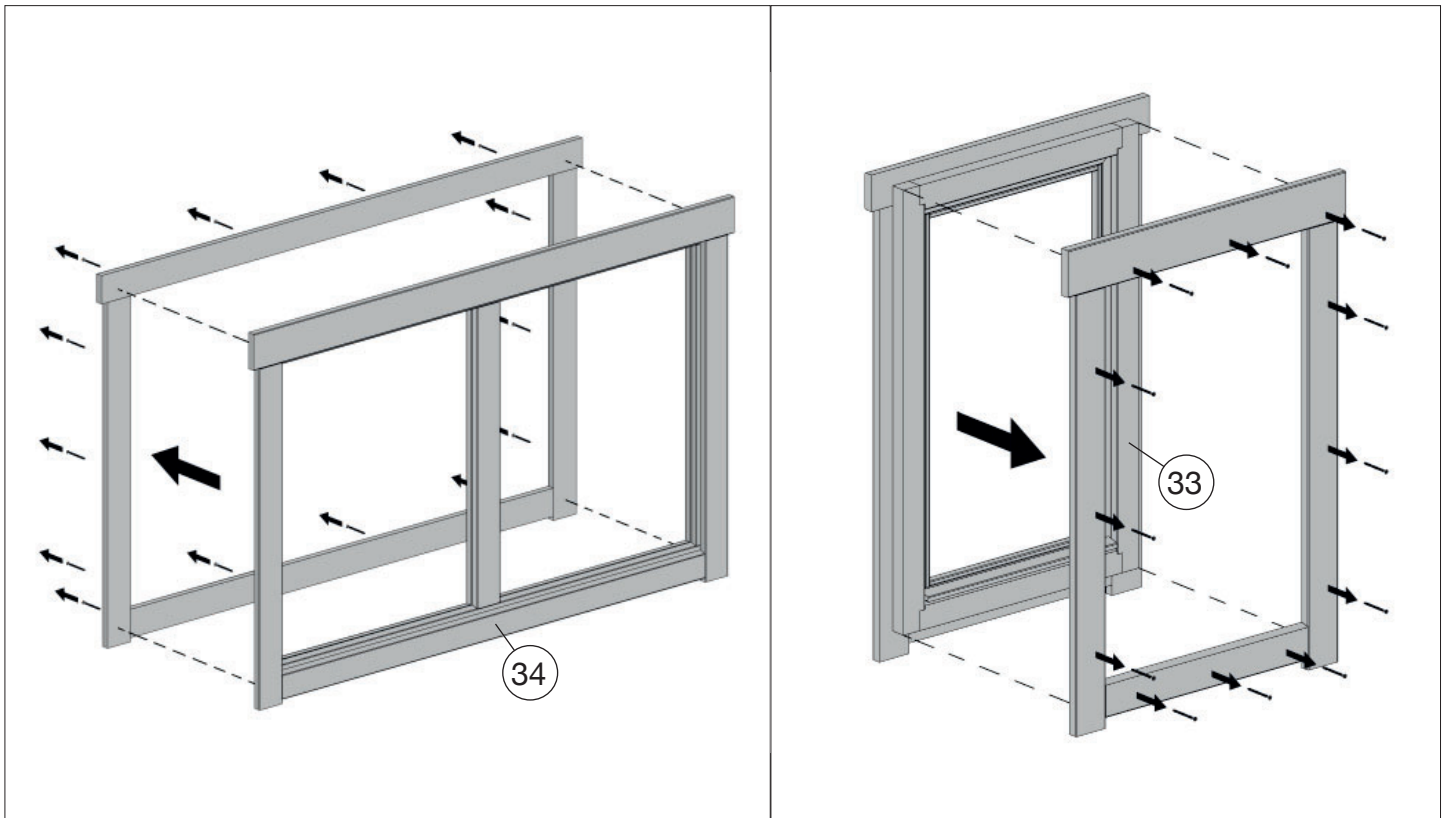

15.2

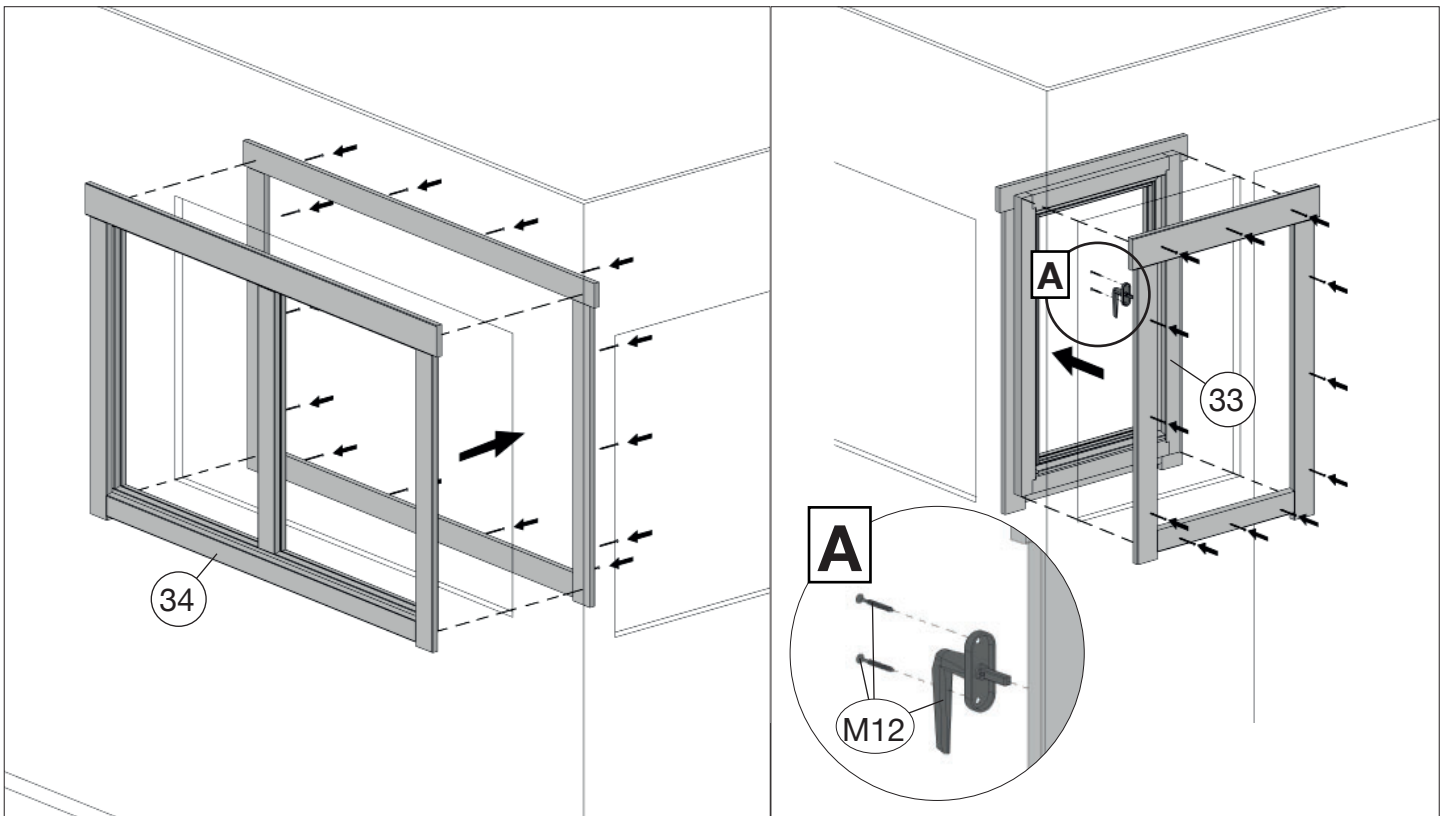

16

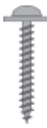
	M11 4,5 x 25
--	---------------------

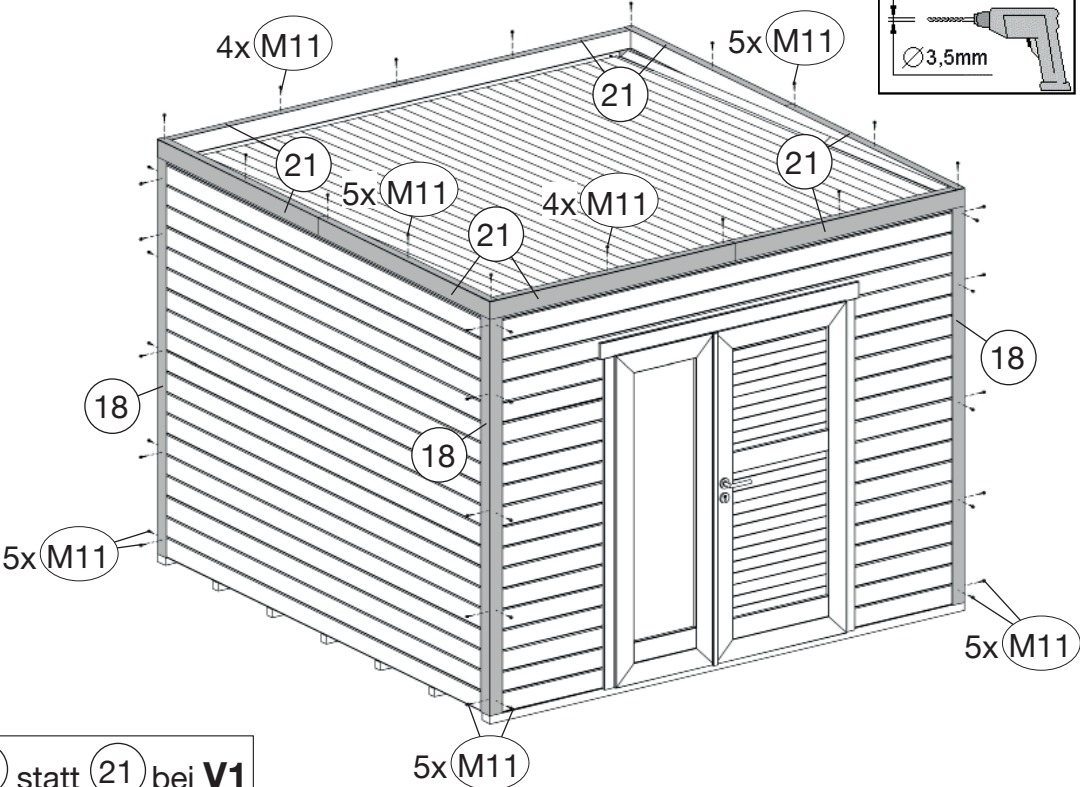

4x M11

5x M11

21

5x M11

4x M11

18

18

18

5x M11

5x M11

5x M11

Pos. 19 statt 21 bei V1

V2

17

	M2 4,0 x 40
---	--------------------

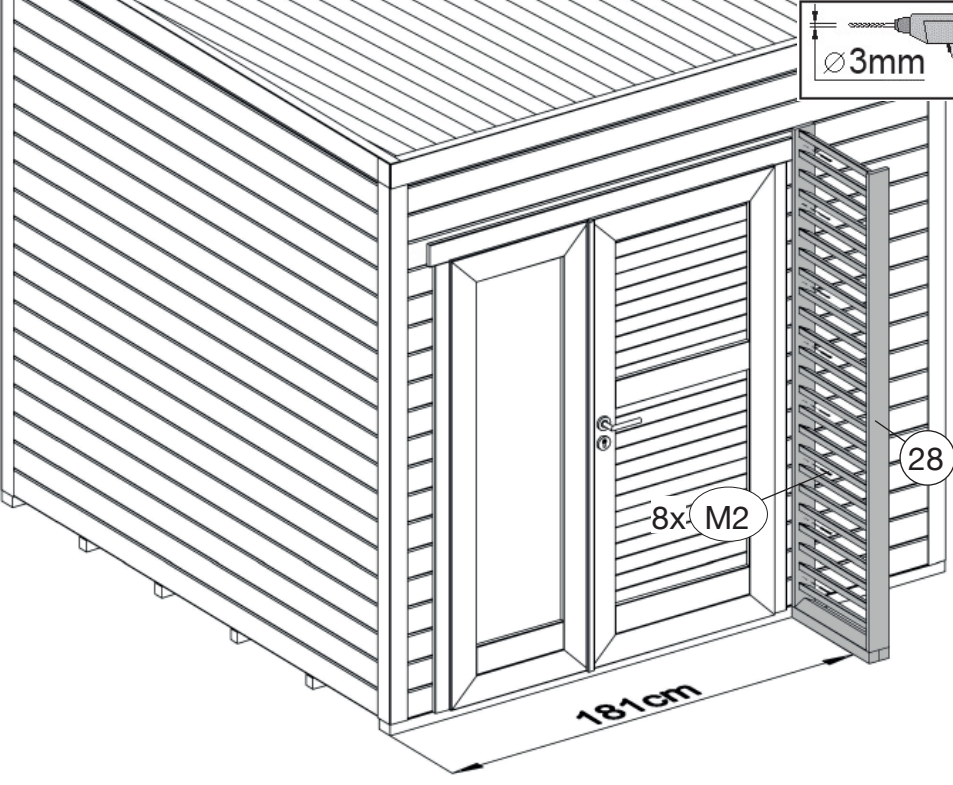

3mm

8x M2

28

181cm

V1

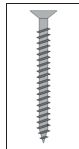
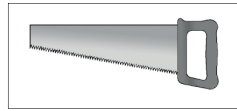

M2 4,0 x 40

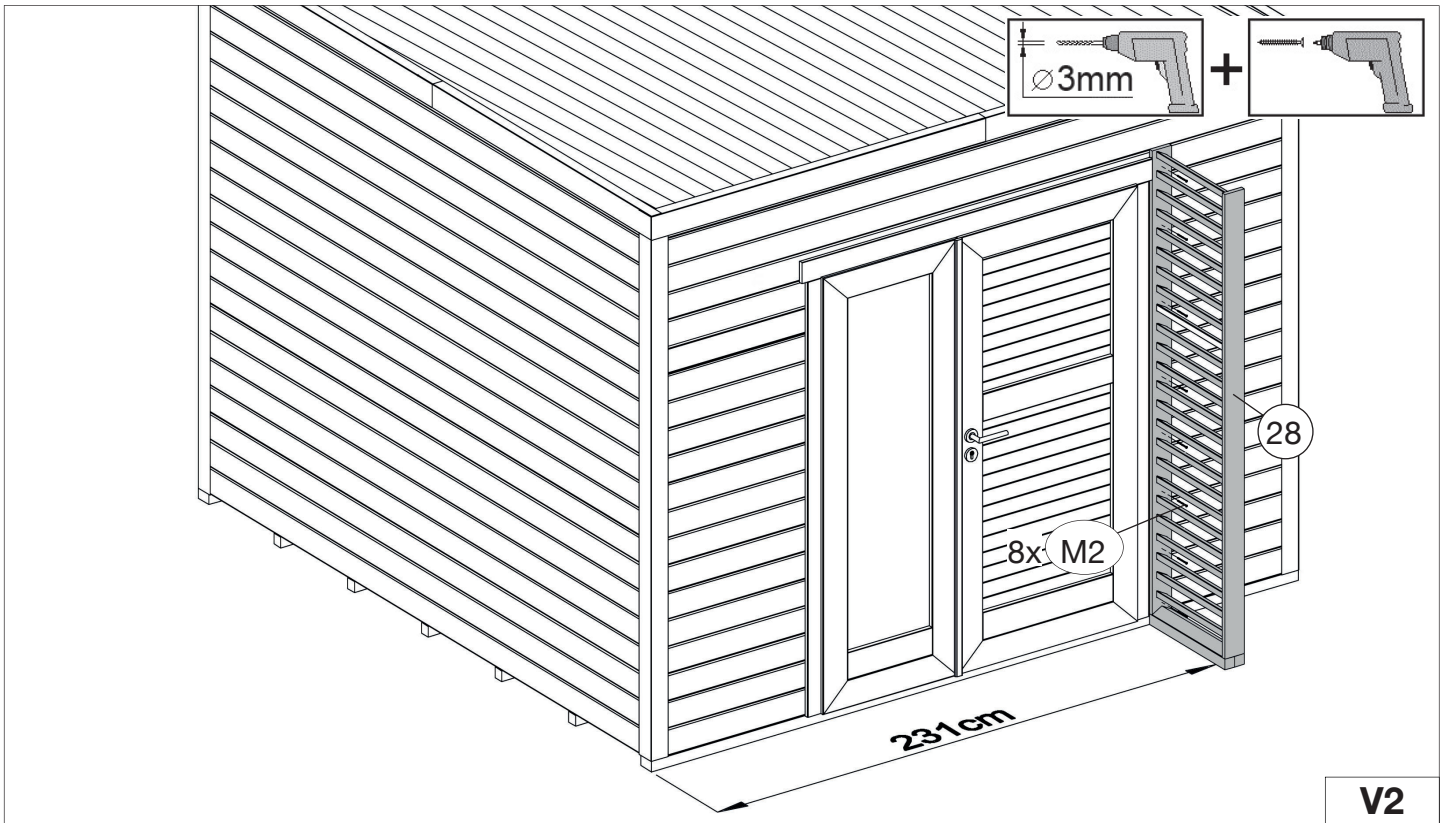

18.1

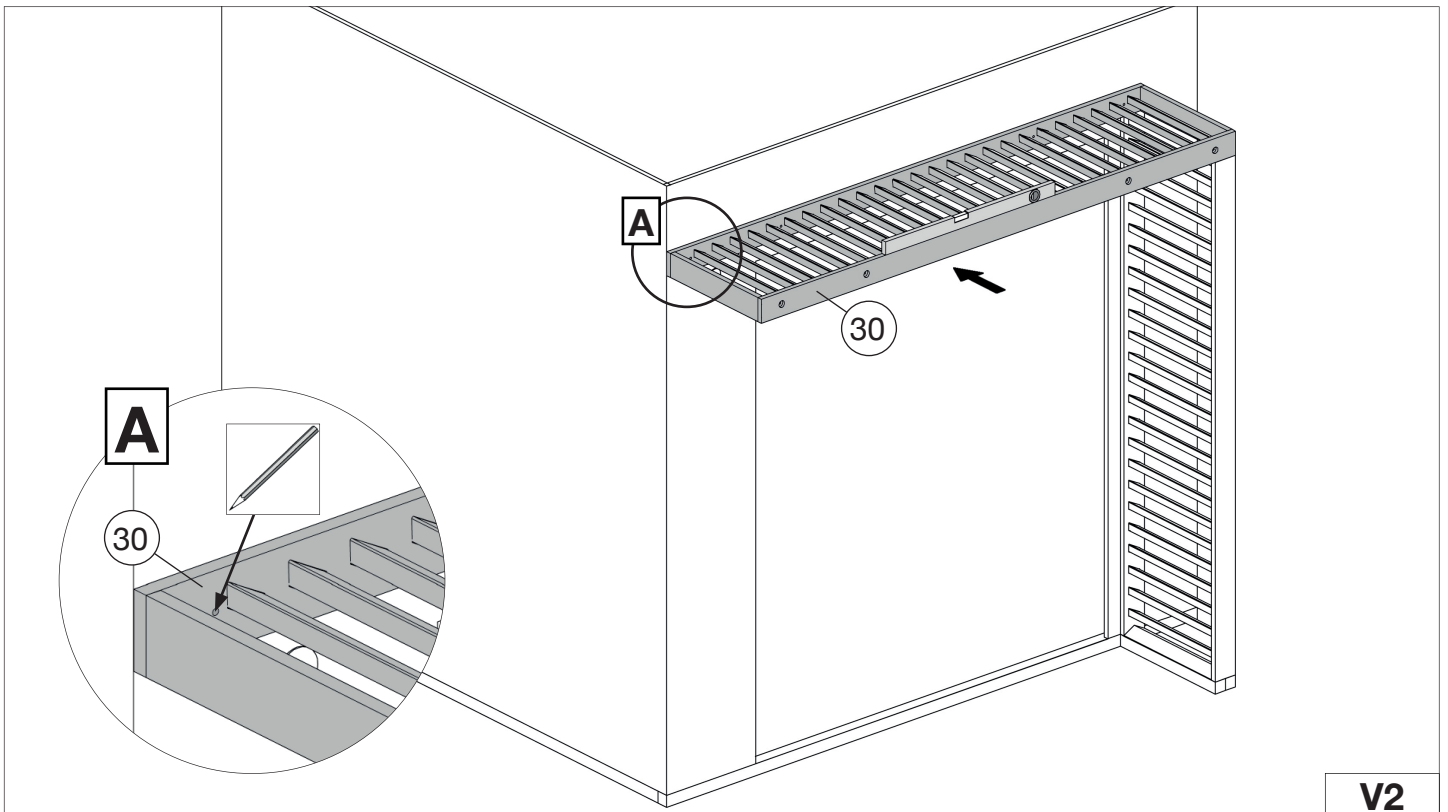
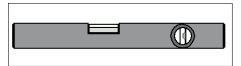

18.2

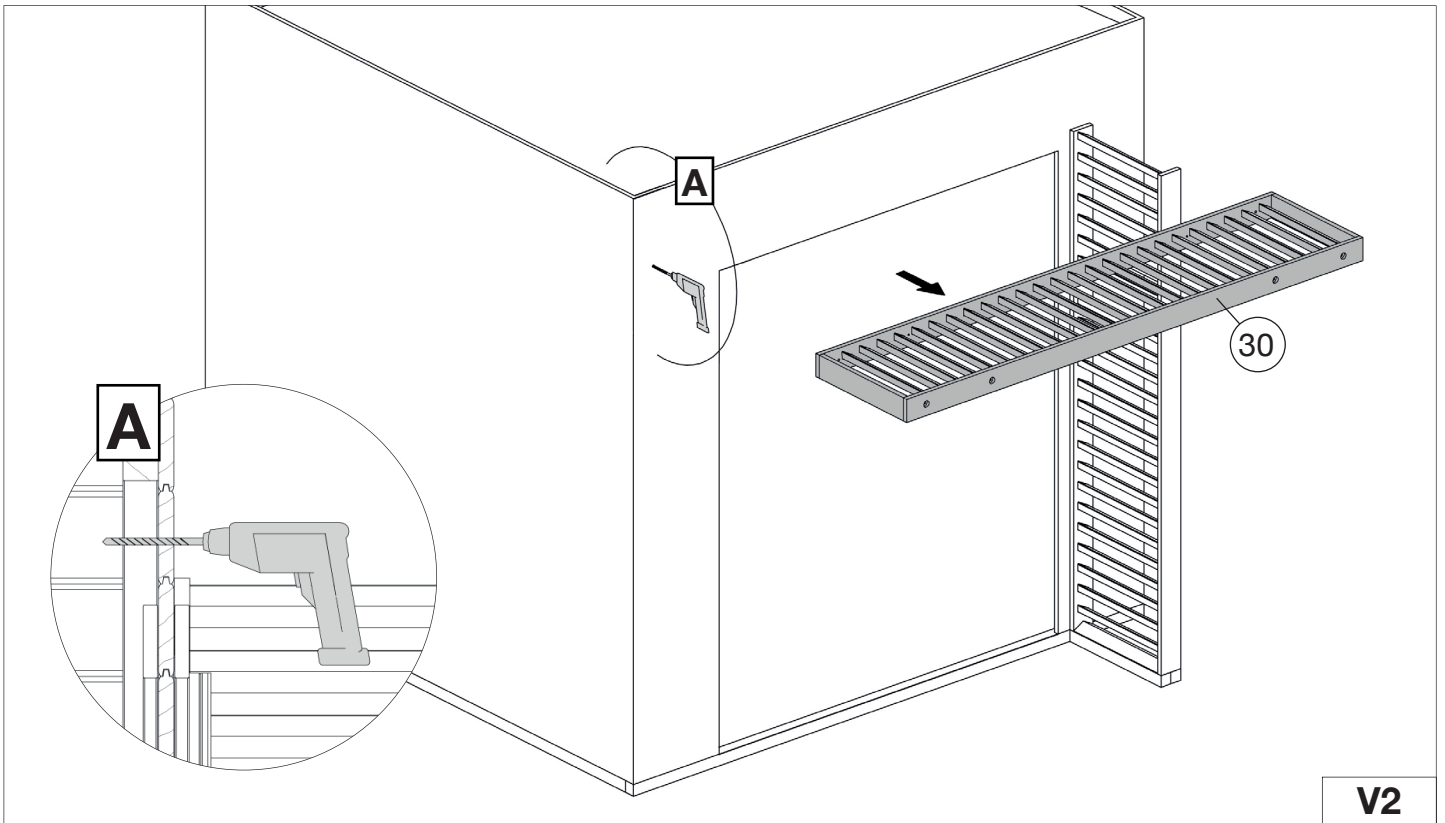

V2

18.3

		M2 4,0 x 40		M7 Ø24		M8 M8
--	--	-------------	--	--------	--	-------

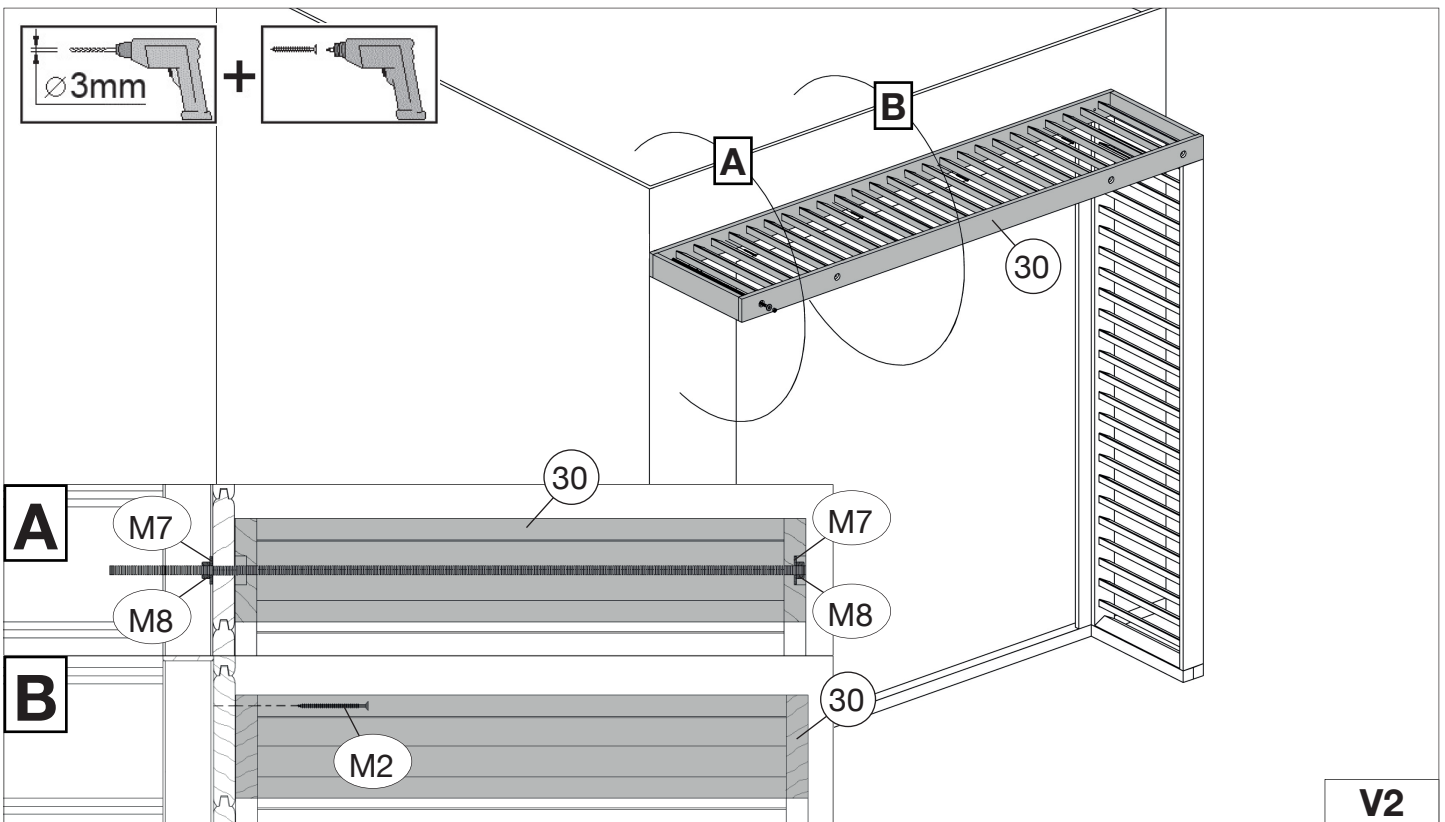

V2

19.1

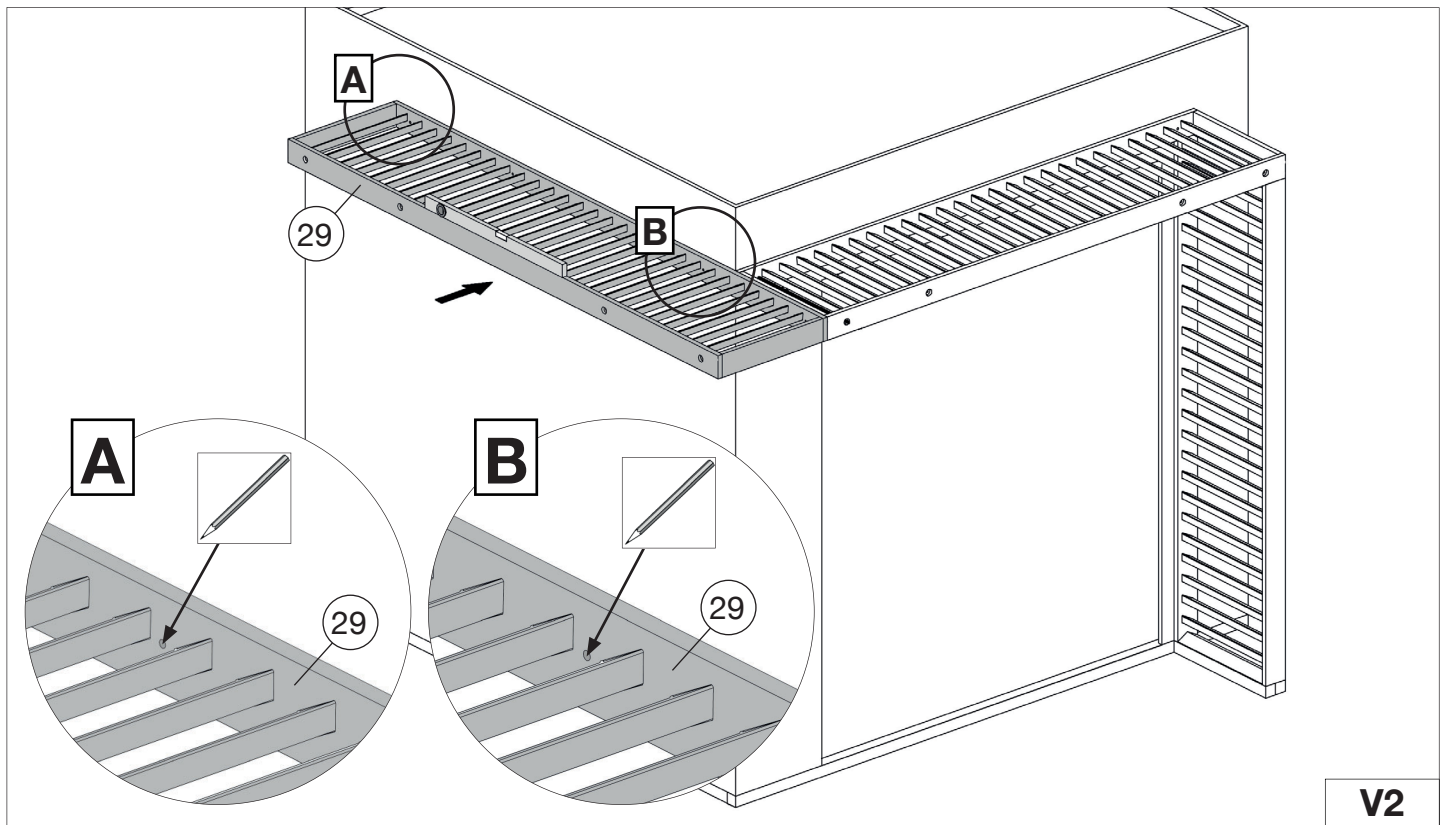
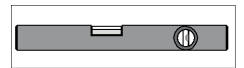

19.2

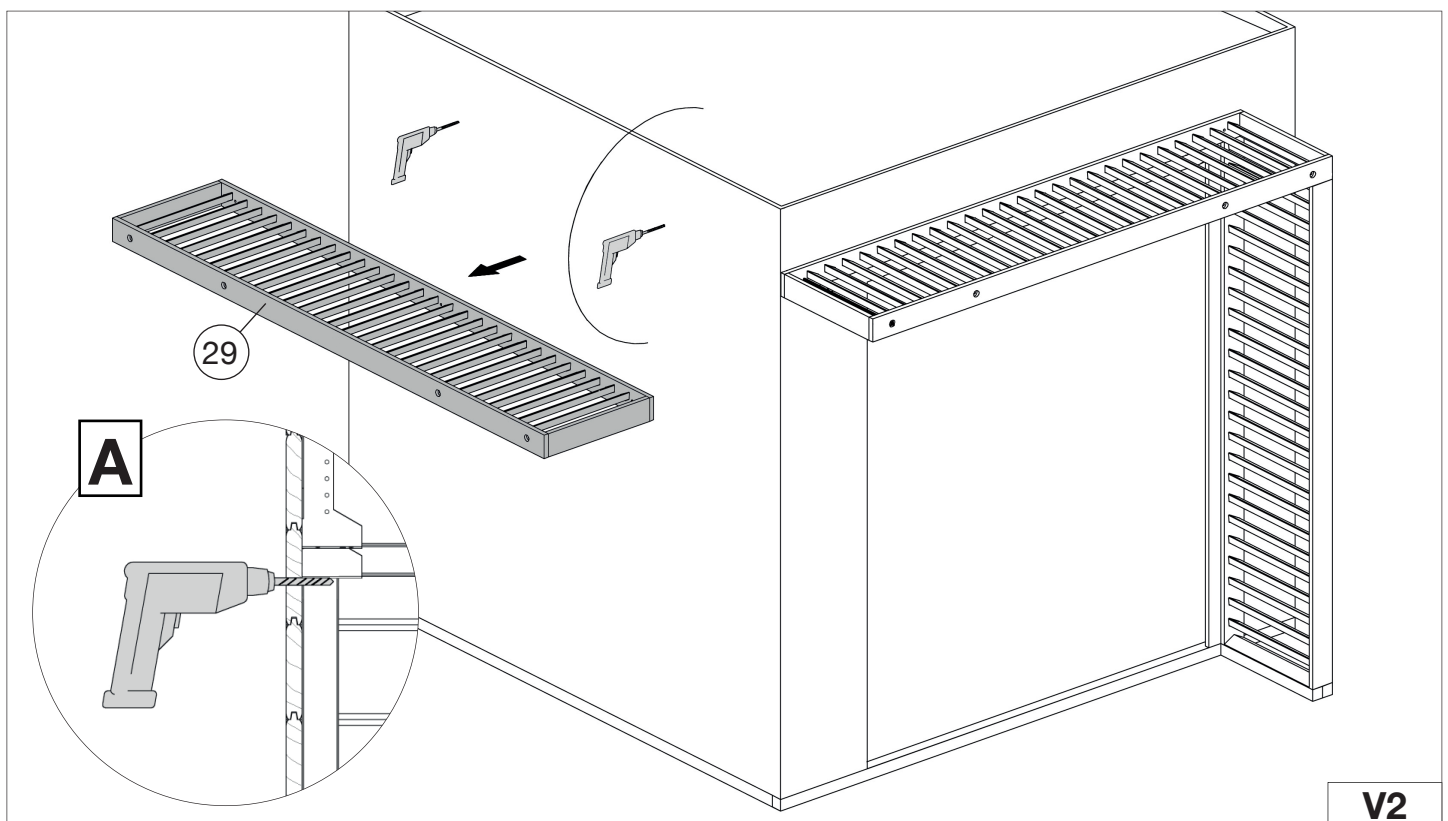

19.3

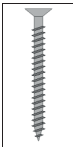
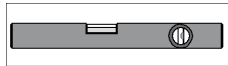

M2	4,0 x 40
M4	3,5 x 30

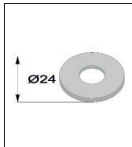

M6	Ø24
----	-----

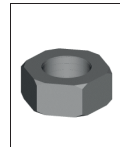

M7	M8
----	----

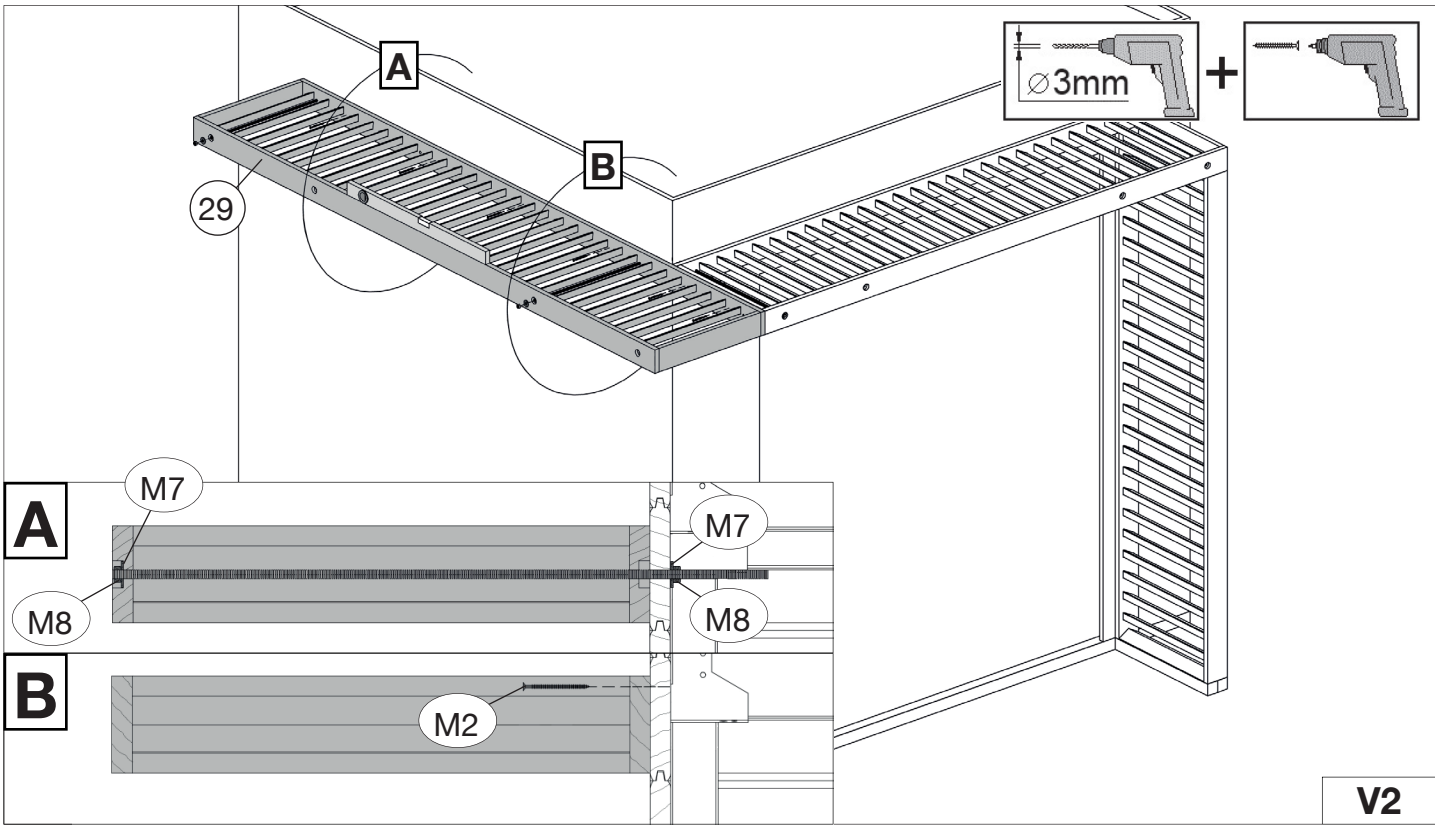

20

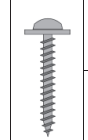

M11	4,5 x 25
-----	----------

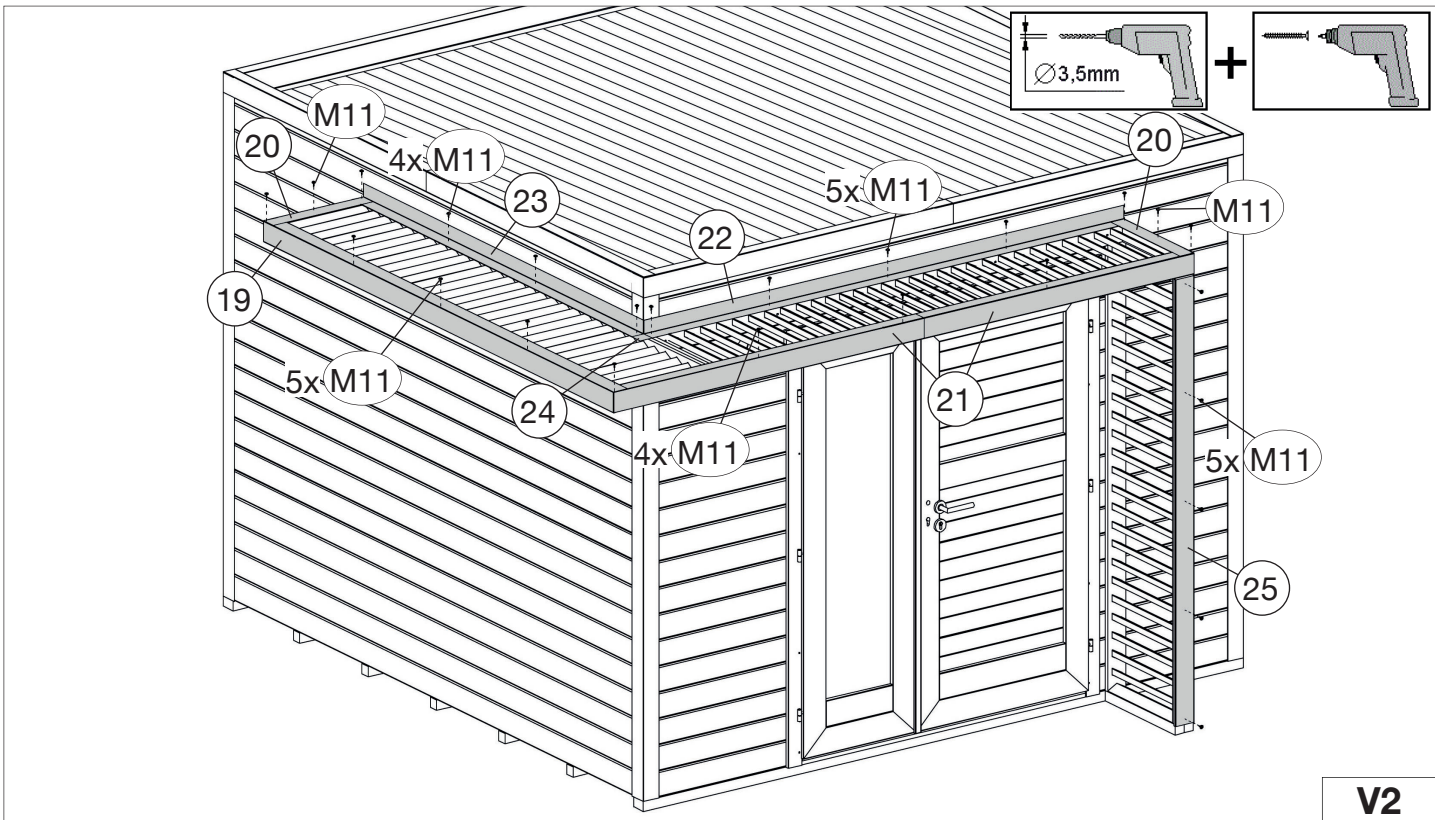

21

waka	M9	Ø50

	M10	2,2 x 9,5

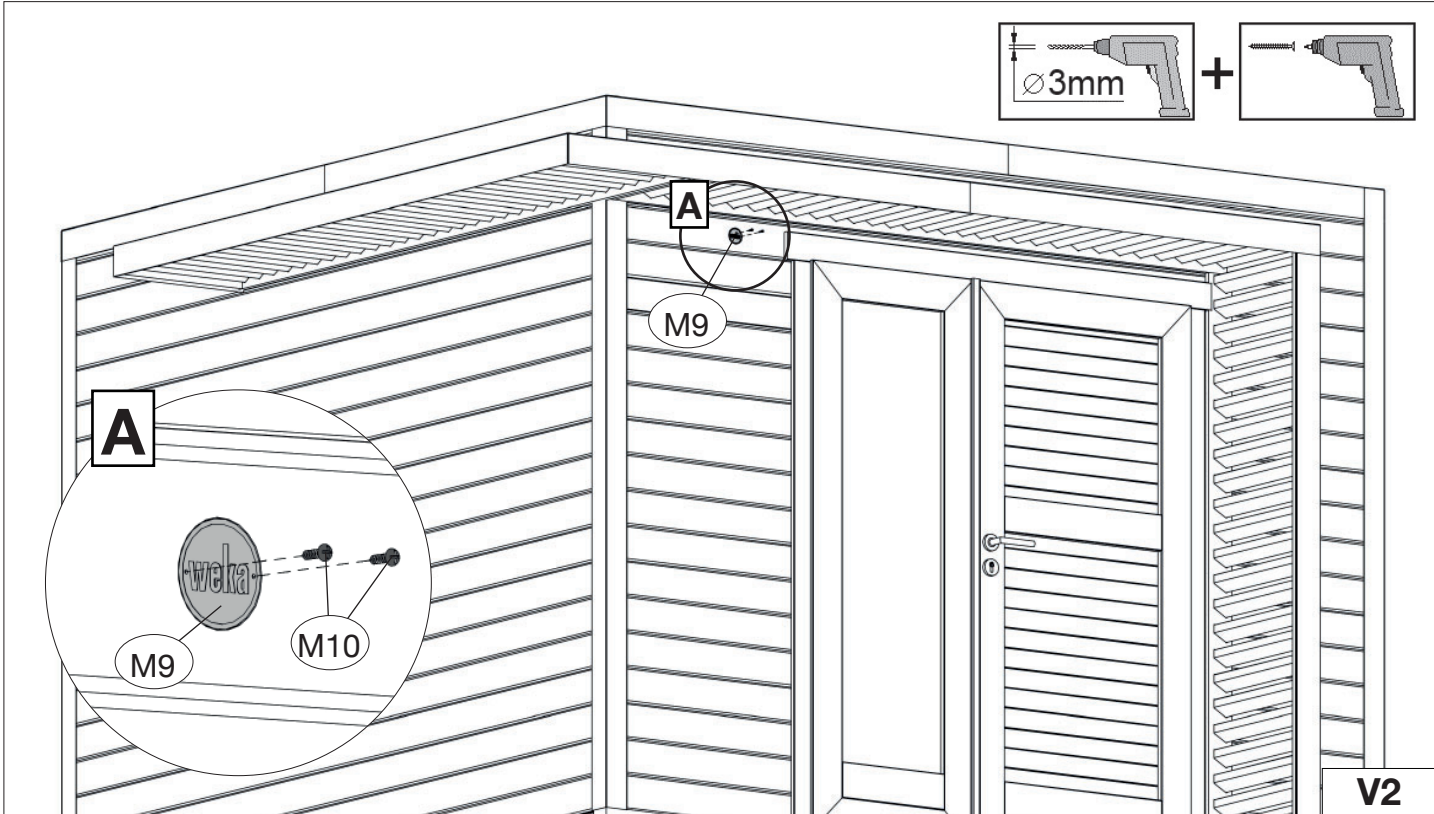
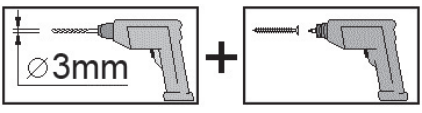

22

	M15	50/100

	M16	3,5 x 16

